

ASME B20.1-2018
(Revision of ASME B20.1-2015)

Safety Standard for Conveyors and Related Equipment

AN AMERICAN NATIONAL STANDARD



**The American Society of
Mechanical Engineers**

ASME B20.1-2018
(Revision of ASME B20.1-2015)

Safety Standard for Conveyors and Related Equipment

AN AMERICAN NATIONAL STANDARD



**The American Society of
Mechanical Engineers**

Two Park Avenue • New York, NY • 10016 USA

Date of Issuance: October 23, 2018

The next edition of this Standard is scheduled for publication in 2021. This Standard will become effective 1 year after the Date of Issuance.

ASME issues written replies to inquiries concerning interpretations of technical aspects of this Standard. Interpretations are published on the ASME website under the Committee Pages at <http://cstools.asme.org/> as they are issued.

Errata to codes and standards may be posted on the ASME website under the Committee Pages to provide corrections to incorrectly published items, or to correct typographical or grammatical errors in codes and standards. Such errata shall be used on the date posted.

The Committee Pages can be found at <http://cstools.asme.org/>. There is an option available to automatically receive an e-mail notification when errata are posted to a particular code or standard. This option can be found on the appropriate Committee Page after selecting "Errata" in the "Publication Information" section.

ASME is the registered trademark of The American Society of Mechanical Engineers.

This code or standard was developed under procedures accredited as meeting the criteria for American National Standards. The Standards Committee that approved the code or standard was balanced to assure that individuals from competent and concerned interests have had an opportunity to participate. The proposed code or standard was made available for public review and comment that provides an opportunity for additional public input from industry, academia, regulatory agencies, and the public-at-large.

ASME does not "approve," "rate," or "endorse" any item, construction, proprietary device, or activity.

ASME does not take any position with respect to the validity of any patent rights asserted in connection with any items mentioned in this document, and does not undertake to insure anyone utilizing a standard against liability for infringement of any applicable letters patent, nor assume any such liability. Users of a code or standard are expressly advised that determination of the validity of any such patent rights, and the risk of infringement of such rights, is entirely their own responsibility.

Participation by federal agency representative(s) or person(s) affiliated with industry is not to be interpreted as government or industry endorsement of this code or standard.

ASME accepts responsibility for only those interpretations of this document issued in accordance with the established ASME procedures and policies, which precludes the issuance of interpretations by individuals.

No part of this document may be reproduced in any form,
in an electronic retrieval system or otherwise,
without the prior written permission of the publisher.

The American Society of Mechanical Engineers
Two Park Avenue, New York, NY 10016-5990

Copyright © 2018 by
THE AMERICAN SOCIETY OF MECHANICAL ENGINEERS
All rights reserved
Printed in U.S.A.

CONTENTS

Foreword	iv
Committee Roster	vi
Correspondence With the B20 Committee	vii
Introduction	ix
Summary of Changes	x
1 Scope	1
2 References	1
3 Intent	1
4 Definitions	2
5 General Safety Standards	7
6 Specific Safety Standards	10
Mandatory Appendix	
I Specifications for Design, Installation, Commissioning, and Periodic Inspection of Vertical Reciprocating Conveyors	17
Figures	
I-3.1-1 Cantilever Design	18
I-3.1-2 Straddle Design	18
I-3.1-3 Four-Post Design	18
I-3.9.2-1 Single-Swing Hinged Gate	19
I-3.9.2-2 Biparting, Double-Swing Hinged Gates	19
I-3.9.2-3 Vertical Rising Gates	20
I-3.9.2-4 Horizontal Sliding Gate	20
I-3.9.2-5 Roll-Up Type Door (Gate)	20

FOREWORD

The first edition of the Safety Standard for Conveyors, Cableways, and Related Equipment was sponsored by the National Conservation Bureau and The American Society of Mechanical Engineers (ASME). It was approved by the American Standards Association [now known as the American National Standards Institute (ANSI)] as American Standard B20.1-1947.

In 1950, the Sectional Committee B20 was reorganized under the sponsorship of the Accident Prevention Department of the Association of Casualty and Surety Companies and ASME. The following four Subcommittees were formed to make specific recommendations for revisions:

- Subcommittee No. 1: Scope and Intent
- Subcommittee No. 2: Nomenclature and Definitions
- Subcommittee No. 3: Portable Conveyors
- Subcommittee No. 4: Conveyors in General

The definitions section was based on the conveyor industry dictionary, Conveyor Terms and Definitions, as prepared by the Technical Committee (now the Engineering Conference) of the Conveyor Equipment Manufacturers Association (CEMA).

The second edition of this Standard, dated April 1955, was submitted in draft form to the Sectional Committee for approval and distributed to industry in general for criticism and comment. Approval was then given by the Sectional Committee, the sponsors, and the American Standards Association. The Standard was designated as American Standard B20.1-1957 on December 4, 1957.

In 1967, the third edition of the Safety Standard for Conveyors and Related Equipment was submitted in draft form to representatives of industry for comment. It was subsequently approved by the Sectional Committee, the sponsors, and ANSI for issuance as American National Standard B20.1-1972 on February 17, 1972.

The fourth edition of the Safety Standard for Conveyors and Related Equipment was undertaken in 1973 to assist the Office of Safety and Health Standards, U.S. Department of Labor, which indicated interest in the Standard.

A change in format from a specification standard to a performance standard was deemed necessary. Simply stated, the Standard describes what end result should be achieved without the limiting specification usually given by a design and without the inclusion of finite material selection or dimensions.

The fourth edition was subsequently approved by the B20 American National Standards Committee, the Secretariat, and ANSI for issuance as American National Standard B20.1-1976 on June 14, 1976.

In accordance with the policy of ANSI, the B20 Committee began working on a revision of B20.1-1976 in February 1980. The fifth edition was approved by the B20 Committee, the sponsor (ASME), and ANSI for issuance as American National Standard B20.1-1984 on March 13, 1984.

Per the procedures outlined and implemented in the fifth edition, the sixth edition was approved by the B20 Committee, the sponsor (ASME), and ANSI for issuance as American National Standard B20.1-1987 on March 11, 1987. The seventh edition was approved for issuance as an American National Standard on March 26, 1990. The eighth edition was approved for issuance as an American National Standard on August 9, 1993.

The ninth edition was a compilation of changes from the 1993 edition, B20.1a-1994, and B20.1b-1995. It was approved for issuance as an American National Standard on May 23, 1997.

The 2000 edition was a compilation of changes from the B20.1a-1997 and B20.1b-1998 addenda. It was approved for issuance as an American National Standard on December 14, 2000.

Following approval by the B20 Committee and ASME, and after public review, ASME B20.1-2003 was approved by ANSI on October 9, 2003. The 2003 edition was a revision to ASME B20.1-2000.

ASME B20.1-2006 was approved by ANSI on September 7, 2006. The 2006 edition was a revision to ASME B20.1-2003.

ASME B20.1-2009 was approved by ANSI on February 2, 2009. The 2009 edition was a revision to ASME B20.1-2006.

ASME B20.1-2012 was approved by ANSI on March 28, 2012. The 2012 edition was a revision to ASME B20.1-2009.

ASME B20.1-2015 was approved by ANSI on September 9, 2015. The 2015 edition was a revision to ASME B20.1-2012.

This Standard shall become effective 1 year from the date of issuance.

Safety standards for mechanical power apparatus are published in ANSI B15.1-2000 (R2008), Safety Standard for Mechanical Power Transmission Apparatus. Safety standards for lockout and tagout procedures are published in ANSI/ASSE Z244.1-2003 (R2014), Control of Hazardous Energy — Lockout/Tagout and Alternative Methods, and OSHA

Standard 29 CFR 1910.147, The Control of Hazardous Energy (Lockout/Tagout). The use of recommendations and guidelines as published by CEMA, Safety Label Brochure No. 201 and Application Guidelines for Vertical Reciprocating Conveyors, published by the Conveyor and Sortation Systems (CSS) of the Material Handling Institute in conjunction with ASME B20.1 is encouraged, as are the above-mentioned standards.

The values stated within this Standard are in both SI and U.S. Customary units, with the latter placed in parentheses. These units are essentially interchangeable, and, depending on the country, as well as industry preferences, the user will determine which values are to be regarded as the standard.

Safety codes and standards are intended to enhance public safety. Revisions result from committee consideration of factors such as technological advances, new data, and changing environmental and industry needs. Revisions do not imply that previous editions were inadequate.

ASME B20.1-2018 was approved by ANSI on June 22, 2018. This 2018 edition is a revision to ASME B20.1-2015.

ASME B20 COMMITTEE

Safety Standard for Conveyors and Related Equipment

(The following is a roster of the Committee at the time of publication of this Standard.)

STANDARDS COMMITTEE OFFICERS

M. T. McGettigan, *Chair*
M. R. Webster, *Vice Chair*
R. Mohamed, *Secretary*

STANDARDS COMMITTEE PERSONNEL

T. M. Berger, Martin Sprocket & Gear
A. C. Bhalerao, Bechtel Corp.
T. Brandlein, Archer Western
J. Campbell, Reily Foods Co.
M. J. Dos Santos, Dos Santos International
D. W. Duff, Material Handling Consulting, LLC
J. J. Galante, Southworth Products Corp.
J. Johnston, Autoquip Corp.
F. J. Loeffler, Jr., Loeffler Engineering Group
D. Mahr, Energy Associates, PC
M. T. McGettigan, Dematic Corp.

J. W. Mensch, KMEC Engineering & Conveying Systems
R. Mohamed, The American Society of Mechanical Engineers
R. W. Parry, Consultant
W. E. Phillips, Jr., Security Matrix, LLC
K. Reese, SICK
R. A. Reinfried, Conveyor Equipment Manufacturers Association
E. A. Sefcik, Vermaport, Ltd.
R. Swinderman, RTodds Engineering, LLC
R. Tschantz, Imperial Technologies, Inc.
M. R. Webster, Pflow Industries, Inc.

CORRESPONDENCE WITH THE B20 COMMITTEE

General. ASME Standards are developed and maintained with the intent to represent the consensus of concerned interests. As such, users of this Standard may interact with the Committee by requesting interpretations, proposing revisions or a case, and attending Committee meetings. Correspondence should be addressed to:

Secretary, B20 Standards Committee
The American Society of Mechanical Engineers
Two Park Avenue
New York, NY 10016-5990
<http://go.asme.org/Inquiry>

Proposing Revisions. Revisions are made periodically to the Standard to incorporate changes that appear necessary or desirable, as demonstrated by the experience gained from the application of the Standard. Approved revisions will be published periodically.

The Committee welcomes proposals for revisions to this Standard. Such proposals should be as specific as possible, citing the paragraph number(s), the proposed wording, and a detailed description of the reasons for the proposal, including any pertinent documentation.

Interpretations. Upon request, the B20 Standards Committee will render an interpretation of any requirement of the Standard. Interpretations can only be rendered in response to a written request sent to the Secretary of the B20 Standards Committee.

Requests for interpretation should preferably be submitted through the online Interpretation Submittal Form. The form is accessible at <http://go.asme.org/InterpretationRequest>. Upon submittal of the form, the Inquirer will receive an automatic e-mail confirming receipt.

If the Inquirer is unable to use the online form, he/she may mail the request to the Secretary of the B20 Standards Committee at the above address. The request for an interpretation should be clear and unambiguous. It is further recommended that the Inquirer submit his/her request in the following format:

Subject:	Cite the applicable paragraph number(s) and the topic of the inquiry in one or two words.
Edition:	Cite the applicable edition of the Standard for which the interpretation is being requested.
Question:	Phrase the question as a request for an interpretation of a specific requirement suitable for general understanding and use, not as a request for an approval of a proprietary design or situation. Please provide a condensed and precise question, composed in such a way that a “yes” or “no” reply is acceptable.
Proposed Reply(ies):	Provide a proposed reply(ies) in the form of “Yes” or “No,” with explanation as needed. If entering replies to more than one question, please number the questions and replies.
Background Information:	Provide the Committee with any background information that will assist the Committee in understanding the inquiry. The Inquirer may also include any plans or drawings that are necessary to explain the question; however, they should not contain proprietary names or information.

Requests that are not in the format described above may be rewritten in the appropriate format by the Committee prior to being answered, which may inadvertently change the intent of the original request.

Moreover, ASME does not act as a consultant for specific engineering problems or for the general application or understanding of the Standard requirements. If, based on the inquiry information submitted, it is the opinion of the Committee that the Inquirer should seek assistance, the inquiry will be returned with the recommendation that such assistance be obtained.

ASME procedures provide for reconsideration of any interpretation when or if additional information that might affect an interpretation is available. Further, persons aggrieved by an interpretation may appeal to the cognizant ASME Committee or Subcommittee. ASME does not “approve,” “certify,” “rate,” or “endorse” any item, construction, proprietary device, or activity.

Attending Committee Meetings. The B20 Standards Committee regularly holds meetings and/or telephone conferences that are open to the public. Persons wishing to attend any meeting and/or telephone conference should contact the Secretary of the B20 Standards Committee.

INTRODUCTION

Accidents resulting from the manual handling of materials have been reduced by the use of conveying and other forms of mechanical handling equipment. A further reduction in the accident rate can be gained by following safe practices in the design, construction, installation, operation, and maintenance of such equipment.

The design and installation of conveyors and conveyor systems should be supervised by qualified engineers. Likewise, the operation and maintenance of conveyors and systems should be supervised by trained personnel.

The purpose of this Standard is to present certain guides for the design, construction, installation, operation, and maintenance of conveyors and related equipment.

Those portions of this Standard relating to maintenance and operation procedures are fully as important as those relating to design and installation. The best design features may be negated by faulty maintenance and operating practices. It is important that operating and maintenance personnel be instructed in recognizing hazards and pertinent safety precautions.

Operation and maintenance instructions in this Safety Standard are intended for general applications. The equipment manufacturer and/or installer should be consulted for specific operating or maintenance instructions.

ASME B20.1-2018 SUMMARY OF CHANGES

Following approval by the ASME B20 Committee and ASME, and after public review, ASME B20.1-2018 was approved by the American National Standards Institute on June 22, 2018.

ASME B20.1-2018 includes the following changes identified by a margin note, **(18)**.

<i>Page</i>	<i>Location</i>	<i>Change</i>
ix	Introduction	Relocated to the front matter
1	Section 1	In fourth paragraph, first sentence revised
1	Section 2	Updated to consolidate reference information
1	Section 3	Second through last paragraphs deleted, and information relocated to the Correspondence With the B20 Committee page in the front matter
2	Section 4	(1) Definitions of <i>antirunaway</i> and <i>brake</i> revised (2) Definitions of <i>conveyor</i> , <i>mobile hopper railcar/hopper bottom truck unloader</i> and <i>hold-down wheels</i> added
8	5.11	Revised
11	6.6.1	Subparagraph (a) revised
14	6.17.2	(1) In para. 6.17.2.1, (e) and (f) added (2) Paragraph 6.17.2.2 revised
15	6.21.1	Subparagraph (a) revised
16	6.23	Added
16	6.24	Added
17	I-3.3	Metric-equivalent values added
18	I-3.5	Revised
18	I-3.6	Metric-equivalent value added
18	I-3.9	Metric-equivalent values added
19	I-4.2	Footnote 2 revised

SPECIAL NOTE: The Interpretations to ASME B20.1 are no longer included in the edition. Interpretations can be accessed on the ASME website under the Committee Pages at <http://cstools.asme.org/>.

SAFETY STANDARD FOR CONVEYORS AND RELATED EQUIPMENT

(18) 1 SCOPE

This Standard applies to the design, construction, installation, maintenance, inspection, and operation of conveyors and conveying systems in relation to hazards. The conveyors may be of the bulk material, package, or unit-handling types, where the installation is designed for permanent, temporary, or portable operation.

This Standard shall apply, with the exceptions noted below, to all conveyor installations.

This Standard specifically excludes any conveyor designed, installed, or used primarily for the movement of people. This Standard does, however, apply to certain conveying devices that incorporate within their supporting structure workstations or operator's stations specifically designed for authorized operating personnel.

This Standard does not apply to conveyors for which specific standards are already in effect, or to equipment such as industrial trucks, tractors, trailers, automatic guided vehicles, tiering machines (except pallet load tierers), cranes, hoists, power shovels, power scoops, bucket drag lines, trenchers, platform elevators designed to carry passengers or an operator, manlifts, moving walks, moving stairways (escalators), highway or railroad vehicles, cableways, tramways, dumbwaiters, material lifts, industrial scissors lifts, pneumatic conveyors, robots, or integral machine transfer devices. Some of the foregoing have specific standards.

The provisions of this Standard shall apply to equipment installed 1 yr after the date of issuance.

(18) 2 REFERENCES

The following list of codes and standards have been cited as references in this Standard. Reference to them does not constitute inclusion of the complete text of such codes or standards as a part of this Standard.

This Safety Standard for conveyors is supplementary to any law or code covering fire or health regulations.

ANSI Z244.1-1982, Personnel Protection — Lockout/Tagout of Energy Sources — Minimum Safety Requirements

Publisher: American National Standards Institute (ANSI), 25 West 43rd Street, New York, NY 10036 (www.ansi.org)

ASME A17.1/CSA B44, Safety Code for Elevators and Escalators

Publisher: The American Society of Mechanical Engineers (ASME), Two Park Avenue, New York, NY 10016-5990 (www.asme.org)

ASSE Z590.3, Guidelines for Addressing Occupational Hazards and Risks in Design and Redesign Processes
Publisher: American Society of Sanitary Engineering (ASSE International), 18927 Hickory Creek Drive, Suite 220, Mokena, IL 60448 (www.asse-plumbing.org)

Application Guidelines for Vertical Reciprocating Conveyors

Publisher: Conveyor and Sortation Systems (CSS), a division of Material Handling Industry (MHI), 8720 Red Oak Boulevard, Charlotte, NC 28217-3992 (www.mhi.org/css)

CEMA 102, Conveyor Terms and Definitions
CEMA Technical Report 2015-01

Publisher: Conveyor Equipment Manufacturers Association (CEMA), 5672 Strand Ct., Suite 2, Naples, FL 34110 (www.cemanet.org)

MIL-STD-882, System Safety

Publisher: Department of Defense, Defense Logistics Agency (DLA), DLA Document Services, Building 4/D, 700 Robbins Avenue, Philadelphia, PA 19111-5094 (<http://quicksearch.dla.mil>)

NEMA Z535.4, Product Safety Signs and Labels

Publisher: National Electrical Manufacturers Association (NEMA), 1300 North 17th Street, Suite 900, Arlington, VA 22209 (www.nema.org)

NFPA 70, National Electrical Code

NFPA 79, Electrical Standard for Industrial Machinery
Publisher: National Fire Protection Association (NFPA), 1 Batterymarch Park, Quincy, MA 02169-7471 (www.nfpa.org)

OSHA Standard 29 CFR 1910.147, The Control of Hazardous Energy (Lockout/Tagout)

Publisher: Occupational Safety & Health Administration (OSHA), U.S. Department of Labor, 200 Constitution Avenue, Washington, DC 20210 (www.osha.gov)

3 INTENT

The intent of this Standard is to provide for safe operation and maintenance of conveying equipment.

(18)

(18) **4 DEFINITIONS¹**

accessible: applies to hazardous objects not guarded or isolated and likely to be contacted inadvertently.

actuator: a device that initiates the action of controls or controllers and is manually operated. The actuator may be a push button, toggle switch, foot pedal, hand lever, hand-set timer, or any other device that performs the described function.

antirunaway: a safety device that stops a declining, inclined, or vertical conveyor and thus prevents it from moving away in the event of a mechanical or electrical failure.

apron pan: one of a series of overlapping or interlocking plates or shapes that, together with others, form the conveyor bed.

automatically controlled: describes the operation by the action of a mechanism that is initiated by some impersonal influence, such as a conveyor that is started by a low-level bin indicator.

backstop: a mechanical device to prevent reversal of a loaded conveyor under action of gravity when forward travel is interrupted.

bed:

(a) that part of a conveyor upon which the load or carrying medium rests or slides while being conveyed

(b) in bulk material conveyors, the mass of material being conveyed

belt idler: a roller or series of rollers that supports the belt of a belt conveyor.

belt tripper: a device incorporating a system of pulleys that causes the conveyor belt to discharge material at one or more points along the length of the conveyor.

boom: a cantilevered member or structure that may be hinged, fixed, or pivoted.

brake: a friction device for slowing down conveyor components, bringing conveyor equipment to a controlled stop, holding traveling or traversing equipment in a selected location, preventing reverse travel, and/or controlling overspeed due to the action of gravity.

bunker: a large bin or compartment for storage of bulk materials.

car unloader: a type of conveyor characterized by a shallow, horizontal loading section that enables it to receive and unload material from hopper bottom cars without requiring a pit or other excavation.

carrier:

(a) a device attached to or hung from trolleys to support the load

(b) the receptacle in which objects are placed for transmittal through a conveying system

(c) the moving part of a vertical or inclined reciprocating conveyor that supports the load

cart: see *truck*.

chain: a series of links pivotally joined together to form a medium for conveying or transmitting motion or power. General classes of chain common to conveyors are detachable, pintle, combination, roller, rivetless, coil, inverted tooth, and bar link chains.

chute: a trough through which bulk materials or objects are directed and lowered by gravity. The trough may be open or enclosed, straight or curved.

control: the system governing the starting, stopping, direction of motion, acceleration, speed, retardation, identification, and function of the moving member in a predetermined manner.

controller: an electromechanical device or assembly of devices for starting, stopping, accelerating, or decelerating a drive or serving to govern in some predetermined manner the power delivered to the drive.

conveying medium: that portion of a conveyor that moves or carries materials, packages, or objects.

conveyor: a horizontal, inclined, or vertical device for moving or transporting bulk material, packages, or objects in a path predetermined by the design of the device and having points of loading and discharge, fixed or selective. Included are skip hoists and vertical reciprocating and inclined reciprocating conveyors. Typical exceptions are those devices known as industrial trucks, tractors, trailers, tiering machines (except pallet load tierers), cranes, hoists, power shovels, power scoops, bucket drag lines, trenchers, platform elevators designed to carry passengers or an operator, manlifts, moving walks, moving stairways (escalators), highway or railway vehicles, cableways, tramways, dumbwaiters, pneumatic conveyors, robots, or integral machine transfer devices.

conveyor, apron: a conveyor in which a series of apron pans forms a moving bed.

conveyor, belt: an endless fabric, rubber, plastic, leather, or metal belt operating over suitable drive, tail end, and bend terminals and over belt idlers or slider bed for handling bulk materials, packages, or objects placed directly upon the belt.

conveyor, bucket: any type of conveyor in which the material is carried in a series of buckets.

conveyor, chain: any type of conveyor in which one or more chains act as the conveying medium; a British term for trolley conveyor.

conveyor, declining: a conveyor transporting down a slope.

¹ Many definitions were extracted from the latest revision of CEMA 102. For definitions of terms other than those defined in [section 4](#), refer to this publication.

conveyor, electrified monorail: a conveyor consisting of a network of tracks or guide rails that may be installed horizontally, vertically, inclined, or in combination with one or more self-propelled cars or trolleys that move independently under automatic control from one point to another within the track network, carrying material in containers or by devices suspended from or attached to the cars or trolleys.

conveyor, en masse: a conveyor, comprised of a series of skeleton or solid flights on an endless chain or other linkage, that operates in horizontal, inclined, or vertical paths within a closely fitted casing for the carrying run. Bulk material is conveyed and elevated in a substantially continuous stream with a full cross section of the casing.

conveyor, extendable: a conveyor that may be lengthened or shortened to suit operating needs.

conveyor, flight: a type of conveyor comprised of one or more endless propelling media, such as chain, to which flights are attached and a trough through which material is pushed by the flights.

conveyor, folding belt: a bulk materials trough belt conveyor that has a longitudinally grooved belt cover. These grooves allow the outer edges of the belt to form flaps. These flaps are folded over the conveyed product on the carry side of the conveyor enclosing the product. The flaps are held in place on top of the product by containment idlers. Folding belt conveyors enclose the conveyed material on the carrying side and contain carryover material on the noncarrying side.

conveyor, horizontal reciprocating: a conveyor that progressively advances material by a back-and-forth motion of its conveying medium. It may be equipped with hinged flights or tilting dogs or pushers. These units operate generally in the range of 0 deg to 30 deg from the horizontal.

conveyor, inclined reciprocating: a reciprocating power- or gravity-actuated unit (not designed to carry passengers or an operator) that receives objects on a carrier. These units operate on inclines generally in the range of 30 deg to 70 deg from the horizontal.

conveyor, live roller: a series of rollers over which objects are moved by the application of power to all or some of the rollers. The power-transmitting medium is usually belting or chain.

conveyor, material encapsulating: a bulk materials trough belt conveyor that has a belt(s) that completely encloses the conveyed product.

conveyor, mobile: a conveyor, supported on a structure, that is movable under its own power and includes, but is not limited to, radial stackers, winged stackers, reclaiming conveyors, and shiploaders. These conveyors normally handle bulk material.

conveyor, mobile hopper railcar/hopper bottom truck unloader: a specialty mobile conveyor characterized by a low-profile tail section designed to fit in the space

between the top of rail and bottom of the railcar hopper outlet gate for unloading railcars or trucks.

conveyor, oscillating: a type of vibrating conveyor having a relatively low frequency and large amplitude of motion, usually powered by a rotating eccentric.

conveyor, overland: a single or series of belt conveyors designed to carry bulk material across country, usually following the general contour of the land.

conveyor, pipe: a bulk materials belt conveyor in which the belt is formed into a circular or oval cross section by the idler arrangement on both the carrying and return sides. This design encloses the conveyed material on the carrying side and contains carryover material on the noncarrying side.

conveyor, portable: a transportable conveyor that is not self-propelled, usually having supports that provide mobility.

conveyor, power and free: a conveying system wherein the load is carried on a trolley or trolleys that are mechanically propelled through part of the system and may be gravity or manually propelled through another part. This arrangement provides a means of switching the free trolleys into and out of adjacent lines. The spur or subsidiary lines may or may not be powered.

conveyor, pusher bar: two endless chains cross-connected at intervals by bars or rotatable pushers that propel the load along the bed or trough of the conveyor.

conveyor, reciprocating: a conveyor where the carrier or pusher moves forward and back, or up and down, in the same plane.

conveyor, roller: a series of rollers supported in a frame over which objects are advanced manually, by gravity, or by power.

conveyor, roller slat: a slat conveyor using rollers for slats.

conveyor, sandwich: a bulk materials trough belt conveyor that uses two separate belts to enclose the product on the carrying side. The two belts are held together with rollers, idlers, or by belt tension. These types of conveyors are generally used at steep conveyor slopes.

conveyor, screw: a conveyor screw revolving in a suitably shaped stationary trough or casing fitted with hangers, trough ends, and other auxiliary accessories.

conveyor, shuttle: any conveyor, such as a belt, chain, apron, screw, etc., in a self-contained structure, movable in a defined path parallel to the flow of the material.

conveyor, slat: a conveyor employing one or more endless chains to which nonoverlapping, noninterlocking spaced slats are attached.

conveyor, square belt: a bulk materials conveyor similar to the pipe conveyor except the belt is folded into a square cross section.

conveyor, suspended tray: a vertical conveyor, having one or more endless chains with suitable pendant trays, cars, or carriers that receives objects at one elevation and delivers them to another.

conveyor, teardrop: a bulk materials belt conveyor where the belt edges are hung close together by a series of rollers that travel on a track system. The belt forms a teardrop shape enclosing the conveyed product. These conveyors are capable of making horizontal curves around a tight radius.

conveyor, tow: an endless belt- or cable-driven system or chain supported by trolleys from an overhead track or running in a track with means for towing floor-supported or rail-guided trucks, dollies, or carts.

conveyor, trolley: a series of trolleys supported from or within an overhead track and connected by endless propelling means, such as chain, cable, or other linkage, with loads usually suspended from the trolleys.

conveyor, tube: see *conveyor, pipe*.

conveyor, vertical articulated: a type of vertical conveyor in which sections of articulated slat conveyor apron form rigid carriers for vertical movement in continuous flow. The carriers are flexible in but one direction, and they assume a vertical position on the noncarrying run to minimize space requirements.

conveyor, vertical chain, opposed shelf type: two or more vertical elevating-conveying units opposed to each other. Each unit consists of one or more endless chains whose adjacent facing runs operate in parallel paths. Thus, each pair of opposing shelves or brackets receives objects (usually dish trays) and delivers them to any number of stations.

conveyor, vertical reciprocating: a reciprocating power- or gravity-actuated unit (not designed to carry passengers or an operator) that receives objects on a carrier and transmits these objects vertically between two or more levels.

conveyor, vibrating: a trough, tube, or other device flexibly supported and vibrated at a relatively high frequency and small amplitude to convey bulk material or objects, usually powered by an electrical or pneumatic impulse.

conveyor, wheel: a series of wheels supported in a frame over which objects are moved manually or by gravity.

conveyor belt: a belt used to carry materials and transmit the power required to move the load being conveyed.

conveyor screw: the material-propelling medium of a screw conveyor generally consisting of an assembly of helical flights mounted on a rotating pipe or shaft.

danger: a combination of hazard and risk (see also *hazard* and *risk*).

deflector:

(a) a device across the path of a conveyor placed at an angle and designed to deflect objects

(b) a plate inserted in the trajectory of a bulk material discharge to change direction

drive: an assembly of the necessary structural, mechanical, and electrical parts that provides the motive power for a conveyor.

drum: a cylindrical or polygonal rim type of wheel around which cable, chain, belt, or other linkage may be wrapped. A drum may be drive or driving. The face may be smooth, grooved, fluted, or flanged.

dumbwaiter: a type of material-lifting device specifically limited to a platform area of 0.8 m² (9 ft²) or less, inside car height of 1.2 m (4 ft) or less, and a hoistway door height of 1.24 m (4 ft 1 in.) or less.²

emergency stop: a stop arising from a sudden and unexpected need and not as a part of the normal operation.

emergency stop device: a device that can be actuated in an emergency situation to stop a conveyor.

enclosed: describes guarding of moving parts in such a manner that inadvertent physical contact by parts of the body is precluded as long as the guard or enclosure remains in place. The guarding may make use of hinged, sliding, or removable doors for inspection or service.

exposed: applies to hazardous objects not guarded or isolated, and capable of being contacted inadvertently.

flight:

(a) plain or shaped plates suitably made for attachment to the propelling medium of a flight conveyor

(b) a term applied to any section of a conveyor in a tandem series

gate: a device or structure by means of which the flow of material may be stopped or regulated; also, a section of conveyor equipped with a hinge mechanism for movable service, often called a hinged section.

grating:

(a) a coarse screen made of parallel or crossed bars to prevent passage of oversize material

(b) a series of parallel and crossed bars used as platform or walkway floors or as coverings for pits and trenches over which traffic may pass; generally removable to permit access to conveying equipment for servicing

(c) a series of parallel or cross bar units, or both, fastened to or propelled by the conveying medium, used for carrying large, lump-sized bulk material or objects; generally used to permit passage of air for cooling or heat to maintain temperature

guard:

(a) a covering, barricade, grating, fence, or other form of barrier used to prevent inadvertent physical contact with operating components, such as gears, sprockets, chains, and belts

(b) a structure mounted below an overhead mounted conveyor to protect personnel from falling materials

² See ASME A17.1/CSA B44 for dumbwaiter safety requirements.

guarded: not exposed to contact, shielded, fenced, enclosed, or otherwise protected by means of suitable enclosures, covers, casings, shields, troughs, railings, or by nature of location so as to reduce risk of personal injury from accidental contact.

guarded by location: describes moving parts so protected by their remoteness from the floor, platform, walkway, or other working level or by their location with reference to frame, foundation, or structure as to reduce risk of accidental contact by persons or objects. Remoteness from regular or frequent presence of public or employed personnel may, in reasonable circumstances, constitute guarding by location. Unprotected danger points and areas that are inaccessible to the operating personnel in the normal performance of their duties shall be considered guarded by location.

hazard: a potential injury producer (see also *danger*).

hold-down wheels: wheels or rubber tires used to hold the belt down when a belt conveyor changes direction without a vertical belt curve. These wheels or tires may be mounted on the belt edge outside the material flow or in the center of the belt. Hold-down wheels that are located within the material stream may be fixed or movable and ride on top of the conveyed product when material is present.

hopper: a box having a funnel-shaped bottom or a bottom reduced in size, narrowed, or necked to receive material and direct it to a conveyor, feeder, or chute.

inactive controls: those controls that are not a part of, or do not contribute to, the present or future contemplated use of the conveyor or system as presently installed and wired.

integral machine transfer device: a part of a machine that loads, unloads, or transfers material (parts) from one location to another within the machine, during processing of the material, and without which the machine could not perform its function. Typically, both the machine and transfer device are supplied together and share the power and control systems.

limit switch: an electrical device by which the movement of a conveyor and allied equipment may be controlled within predetermined limits.

material lift: an elevator that has been designed/modified for the purpose of transporting materials that are manually or automatically loaded or unloaded (see ASME 17.1 for safety requirements).

nip point: a point at which a machine element moving in line meets a rotating element in such a manner that it is possible to nip, pinch, squeeze, or entrap a person or objects coming into contact with one of the two members. The same definition holds for the similar point with respect to two rotating parts or two converging parts in linear movement.

operator's station: location at which actuators are placed for the purpose of starting, stopping, reversing, or otherwise controlling the conveyor or system of conveyors in the course of normal operation.

overload device: a mechanical or electrical device designed to disconnect the driven equipment from the driving equipment in the event of an overload on the conveyor.

platform: a working space for persons, elevated above the surrounding floor or ground (such as a balcony) for the operation of machinery and equipment.

prevent: when used in a context such as to prevent access or to prevent physical contact, means to impede or block; when used in the context such as to prevent injury, means to reduce the chances of, but does not imply that an injury cannot occur.

qualified person: a person who, by possession of a recognized degree or certificate of professional standing or by extensive knowledge, training, and experience, has successfully demonstrated his/her ability to solve problems relating to the subject matter and work.

rail:

(a) one of the longitudinal members in a conveyor frame

(b) the supporting surface under the wheels or rollers of a chain conveyor

(c) the supporting track for equipment mounted on wheels, such as belt tripper, weigh larry, etc.

(d) the vertical members that guide the pendant trays, cars, or carriers in a suspended vertical tray conveyor

rail clamp: an attachment or device for clamping a mobile conveyor or belt tripper to the rail to hold it in a fixed location.

railing guard (guardrail): a structure consisting of rails and posts, including top rail, post, and, where required, toeboards.

rail stop: a stop mounted on the conveyor rails to limit the travel of traversing machinery.

rated capacity: the capacity at the rated speed, as established by the manufacturer or a qualified person, at which safe and satisfactory service can be expected.

rated speed: the speed of the conveyor, as established by the manufacturer or a qualified person, at which safe and satisfactory service can be expected.

remote control: any system of controls in which the actuator is situated in a remote location.

remote location: any location, with respect to the conveyor, from which the presence or position of personnel relative to the conveyor cannot be readily determined from the operator's station.

risk: the likelihood of encountering a hazard of a specified severity. (See also *danger*.)

risk assessment: systematic process to identify and evaluate the potential hazards that may be involved with equipment or processes in a projected activity or undertaking.

risk reduction/mitigation: process to reduce the probability of encountering a hazard or to reduce the severity of a risk to an acceptable level or point.

roller:

(a) a revolving cylinder or wheel over which something is moved. The face may be straight, tapered, crowned, concave, or flanged and corrugated, ribbed, or fluted.

(b) a component part or roller chain in which it may serve only to reduce frictional loss occurring as the chain passes over the sprockets. Rollers may also serve as the rolling support for the chain and the load being conveyed.

(c) the rotating element upon which a conveyor belt or chain or the object being transported is carried.

roller turn: a series of vertical rollers mounted in a frame to guide conveyor chain around a horizontal curve.

safety device: a mechanism or an arrangement placed in use for the specific purposes of preventing an unsafe condition, preventing the continuation of an unsafe condition, warning of an unsafe condition, or limiting or eliminating the unsafe effects of a possible condition.

shall: as used in the context of a provision of this Standard, indicates that the provision is mandatory and must be followed.

shear point or line: the point at which, or the line along which, a moving part meets or passes close enough to a stationary or moving part or object so that part of the human body can be caught, trapped, or pinched between them.

shield guard: a full or partial enclosure or cover, either framed or solid, made from material sufficiently rigid to prevent accidental contact with moving parts.

should: as used in the context of a provision of this Standard, indicates a recommendation, the advisability of which depends on the facts in a particular situation.

skip bucket: the tub or bucket used for containing the material conveyed by a skip hoist.

skip hoist: a bucket or car operating up and down a defined path receiving, elevating, and discharging bulk materials.

skirtboard: a conveyor accessory located at a conveyor transfer point intended to confine material to a limited area on the belt and to reduce spillage and dust. It typically consists of structural support components parallel with, and inboard from, each conveyor edge that serves as the mounting for a flexible sealing member. It may also include devices with wear-resistant linings to funnel material into the loading area.

slat: a member supported between chains in a slat conveyor; the series of slats form the conveying medium.

snub roller: any pulley used to increase the arc contact between a belt and drive or trail pulley.

spill guard: a stationary device of sufficient strength and capacity to catch, retain, and contain any reasonably foreseeable spillage from a conveyor passing overhead that might cause personal injury.

stacker: a conveyor adapted to piling or stacking bulk materials, packages, or objects.

switch:

(a) a device for connecting two or more continuous package conveyor lines

(b) an electrical control device

(c) a mechanism that transfers a trolley, carrier, or truck from one track to another at a converging or diverging section

switch, slack cable: a device installed to automatically shut off the power supply when the hoisting cable becomes slack or has slack due to accident or jamming.

take-up: (also spelled *takeup*) the assembly of the necessary structural and mechanical parts that provides the means to adjust the length of belts, cables, chains, etc., to compensate for stretch, shrinkage, or wear and maintain proper tension.

terminal: a term normally applied to the extreme ends of a belt system, i.e., head and tail pulleys.

tow pin: a movable or fixed member on a truck, dolly, or cart used to engage the power system on a tow conveyor.

tracks: the beams, shapes, or formed section on which trolleys, rollers, shoes, or wheels roll or slide while being propelled.

transfer car: any wheeled device used for transferring loads from one conveyor line to another; may be manually or automatically operated.

transfer mechanism: any mechanism that transfers objects onto or off a conveyor line or from one conveyor line to another.

tray: a car, carrier, or pallet, usually suspended from the moving element of the conveyor, used to carry conveyed loads.

tread plate: a plate of suitable size fitted between conveyor rollers to permit persons to use it as a working or walking surface.

trolley: an assembly of wheels, bearings, and brackets used for supporting and moving suspended loads or carrying load-connecting and load-conveying elements, such as chain, cable, or other linkage.

truck:

(a) an assembly that supports another unit in either a fixed or adjustable position and that provides mobility

(b) a wheeled vehicle that can be detached from a conveying medium (usually chain) and pushed by hand

walkway: an elevated passageway for persons above the surrounding floor or ground level, including catwalks, footwalks, runways, and elevated walkways.

workstation: a physical location where a person is normally positioned, which is located by design and supported with facilities necessary for a person to perform prescribed work duties. This position would not apply to maintenance location.

5 GENERAL SAFETY STANDARDS³

5.1 Application

Conveyor equipment shall be used to convey only the specified commodities or materials within the rated capacity and the rated speed. Where special use is not indicated, or ratings are not available, good industry practice shall be used.

5.2 Maintenance (Repair)

(a) Maintenance and service shall be performed by qualified and trained personnel.

(b) Where lack of maintenance and service would cause a hazardous condition, the user shall establish a maintenance program to ensure that conveyor components are maintained in a condition that does not constitute a hazard to personnel.

(c) No maintenance or service shall be performed when a conveyor is in operation except as provided in [paras. 5.3](#) and [5.4](#).

(d) When a conveyor is stopped for maintenance or service, the starting devices, prime movers, or powered accessories shall be locked or tagged out in accordance with a formalized procedure designed to protect all persons or groups involved with the conveyor against an unexpected restart. Personnel should be alerted to the hazard of stored energy, which may exist after the power source is locked out. Refer to ANSI Z244.1-1982 and OSHA Standard 29 CFR 1910.147.

(e) All safety devices and guards shall be replaced before starting equipment for normal operation.

5.3 Lubrication

(a) Conveyors shall not be lubricated while in operation unless it is impractical to shut them down for lubrication. Only trained and qualified personnel who are aware of the hazards of the conveyor in motion shall be allowed to lubricate a conveyor that is operating.

(b) Where the drip of lubricants or process liquids on the floor constitutes a hazard, drip pans or other means of eliminating the hazard shall be provided.

5.4 Adjustment or Maintenance During Operation

When adjustment or maintenance must be done while equipment is in operation, only trained and qualified personnel who are aware of the hazard of the conveyor in motion shall be allowed to make the adjustment or perform the maintenance or service.

5.5 Backstops and Brakes

Antirunaway, brake, or backstop devices shall be provided on all incline, decline, or vertical conveyors, where the effect of gravity will allow uncontrolled lowering of the load and where this movement will cause a hazard to personnel.

5.6 Overload Protection

Where overload conditions would cause damage to equipment that could result in a personal injury, overload devices or suitable warning means shall be provided.

5.7 Gates and Switches

(a) Power-positioned gate and switch sections shall be provided with devices that will prevent these sections from falling in case of power failure.

(b) Means shall be provided on all gate and switch sections to prevent conveyed material from discharging into the open area created by lifting of the gate or switch.

5.8 Counterweights

When counterweights are supported by belts, cables, chains, and similar means, weights shall be confined in an enclosure to prevent the presence of personnel beneath the counterweight. As an alternative, the arrangement shall provide a means to restrain the falling weight in case of failure of the normal counterweight support.

5.9 Guards and Guarding

5.9.1 General Requirements of Guarding

5.9.1.1 Guarding. Where necessary for the protection of personnel from hazards, all exposed moving machinery parts that present a hazard to personnel at workstations or operators' stations shall be mechanically or electrically guarded or guarded by location or position.

5.9.1.2 Interfacing of Equipment. When two or more pieces of equipment are interfaced, special attention shall be given to the interfaced area to ensure the presence of adequate guarding and safety devices.

5.9.1.3 Guarding Exceptions. Wherever conditions prevail that would require guarding under this Standard but such guarding would render the conveyor unusable, prominent warning means, such as signs or warning lights, shall be provided in the area or on the equipment in lieu of guarding.

³ IMPORTANT: The general safety standards in [section 5](#) form a part of, and must be used with, the specific standards in [section 6](#).

5.9.1.4 Maintenance of Guards and Safety Devices.

Guards and safety devices shall be maintained in a serviceable and operational condition. Warning signs provided in accordance with [para. 5.9.1.3](#) shall be maintained in a legible/operational condition.

5.9.2 Guarding by Location or Position

(a) Remoteness from frequent presence of public or employed personnel shall constitute guarding by location.

(b) Overhead conveyors, such as trolley conveyors and hanger-suspended tray conveyors, for which guarding would render the conveyor unusable or would be impracticable, shall have prominent and legible warnings posted in the area or on the equipment, and where feasible, lines shall be painted on the floor delineating the danger area.

(c) When a conveyor passes over a walkway, roadway, or workstation, it is considered guarded by location if all moving parts are at least 2.44 m (8 ft) above the floor or walking surface or are otherwise located so that personnel cannot inadvertently come in contact with hazardous moving parts.

(d) Although overhead conveyors may be guarded by location, spill guards, pan guards, or equivalent shall be provided if material may fall off the conveyor and endanger personnel.

5.9.3 Guarding of Nip and Shear Points. In general, nip and shear points shall be guarded unless other means to ensure safety are provided. See [section 6](#) for specific conveyors.

5.10 Headroom

(a) When conveyors are installed above exit passageways, aisles, or corridors, there shall be provided a minimum clearance of 2 m (6 ft 8 in.) measured vertically from the floor or walking surface to the lowest part of the conveyor or guards.

(b) Where system function will be impaired by providing the minimum clearance of 2 m (6 ft 8 in.) through an emergency exit, alternate passageways shall be provided.

(c) It is permissible to allow passage under conveyors with less than 2 m (6 ft 8 in.) clearance from the floor for other than emergency exits if a suitable warning indicates low headroom.

(18) 5.11 Controls

5.11.1 Electrical Code. All electrical installations and wiring shall conform to NFPA 70 (Article 670 and other applicable articles) and NFPA 79.

5.11.2 Control Station

(a) Control stations should be so arranged and located that the operation of the affected equipment is visible from them. Control stations shall be clearly marked or labeled to indicate the function controlled.

(b) A conveyor that is not completely visible from the control station, is automatically controlled, or must be controlled from a remote location, shall not be started until personnel in the area are alerted by a signal or designated person that the conveyor is about to start. A signal is not required at locations on the conveyor if a risk assessment has determined that the design, function, and operation of the conveyor do not present a hazard to personnel.

(1) An audible device or devices shall be provided that can be clearly heard at all hazardous points along the conveyor where personnel may be present. The audible warning shall be actuated by the controller device starting the conveyor and continue for a required period of time before the conveyor starts. A flashing light or similar visual warning may be used in conjunction with, or in place of, the audible device if a visual warning is more effective.

(2) Where system function would be seriously hindered or adversely affected by the required time delay, or where the intent of the warning may be misinterpreted (i.e., a work area with many different conveyors and allied devices), a clear, concise, and legible warning sign shall be provided. The warning sign shall indicate that conveyors and allied equipment may be started at any time, danger exists, and personnel must keep clear. These warning signs shall be provided along the conveyor at areas not guarded by position or location.

(c) Stop or emergency stop push buttons shall be located at each operator control station. Emergency-stop devices shall be furnished in drive areas, loading areas, transfer points, and other potentially hazardous locations on remotely and automatically controlled conveyors where the operator stations are not manned or are beyond the voice or visual contact from the control station.

(1) All such emergency stop devices shall be easily identifiable in the immediate vicinity of such locations unless guarded by location, position, or guards. An emergency stop device is not required at locations on the conveyor if a risk assessment has determined that the design, function, and operation of the conveyor do not present a hazard to personnel.

(2) The emergency stop device shall act directly on the control of the conveyor concerned and not depend on the stopping of any other equipment. The emergency stop devices shall be installed so that they cannot be overridden from other locations.

(d) Inactive and unused actuators, controllers, and wiring should be removed from control stations and panel boards, together with obsolete diagrams, indicators,

control labels, and other material that may confuse the operator.

5.11.3 Safety Devices. All safety devices, including wiring of electrical safety devices, shall be arranged to operate such that a power failure will not result in a hazardous condition.

5.11.4 Emergency Stops and Restarts. Conveyor controls shall be so arranged that, in case of emergency stop, manual reset or start at the location where the emergency stop was initiated shall be required for the conveyor(s) and associated equipment to resume operation.

Before restarting a conveyor that has been stopped because of an emergency, an inspection of the conveyor shall be made and cause of the stoppage determined. The starting device shall be locked or tagged out before any attempt is made to remove the cause of the stoppage, unless operation is necessary to determine the cause or safely remove the stoppage. Refer to ANSI Z244.1-1982 and OSHA Standard 29 CFR 1910.147.

5.12 Operation

(a) Only a trained person shall be permitted to operate a conveyor. Training shall include instruction in operation under normal conditions and emergency situations. This provision does not apply to the interface of the public with conveyors intended for public use, such as at checkout counters.

(b) Where safety is dependent upon stopping or starting devices or both, they shall be kept free of obstructions to permit ready access.

(c) The area around loading and unloading points shall be kept clear of obstructions that could endanger personnel.

(d) No person shall ride on a conveyor, except on a slow-moving assembly conveyor at 0.4 m/s (80 ft/min) maximum or on a conveyor that incorporates a station specifically designed for operating personnel.

(e) Personnel working on or near a conveyor shall be instructed as to the location and operation of pertinent stopping devices.

(f) A conveyor shall be used to transport only loads it is designed to handle safely.

(g) Under no circumstances shall the safety characteristics of the conveyor be altered if such alterations would endanger personnel.

(h) Routine inspections and corrective maintenance measures shall be conducted to ensure that all guards and safety features are retained and function properly.

(i) Personnel should be alerted to the potential hazard of entanglement in conveyors caused by items such as long hair, loose clothing, and jewelry.

(j) Conveyors shall not be maintained or serviced while in operation unless proper maintenance or service requires the conveyor to be in motion. In this case, per-

sonnel shall be made aware of the hazards and how the task may be safely accomplished.

5.13 Transfer, Loading, and Discharge Points

(a) At transfer, loading, and discharge points where unconfined and uncontrolled free fall of material can result from flooding, ricocheting, overloading, trajectory, leakage, or a combination thereof, such unconfined and uncontrolled free fall of material shall be prevented if it would create a hazard to personnel.

(b) In the absence of a guard or barrier specifically erected to protect personnel, warnings shall be provided to restrict unauthorized personnel from entering hazardous loading, unloading, and transfer areas.

5.14 Hoppers and Chutes

(a) All openings to hoppers and chutes shall be guarded to prevent personnel from accidentally falling or stepping into them or allowing any part of their body to make contact with conveyors below them. Where guards are not practical, warning signs shall be posted. If the hopper or chute is equipped with a grating to protect against contacting the conveyors below, such grating will be considered as sufficient guarding provided that one dimension of the opening does not exceed 50 mm (2 in.).

(b) Dump hoppers having the hopper flush with the floor and which, by their use cannot be guarded, shall be equipped with grating having a maximum opening of 50 mm (2 in.) and be heavy enough to withstand any load of personnel or trucks, etc., that may be imposed on it. If the openings in the grating are larger or no grating is provided, temporary railing guard shall be placed around ground level hoppers when dumping operations are not in progress. During dumping operations, warning signs shall be placed in conspicuous locations warning personnel of an open pit. If there is a need to give operators of trucks, loaders, or bulldozers a reference to the hopper location, guide posts shall be used.

5.15 Fire Safety

This Standard is not intended to address fire-related considerations. Applicable national, state, and local codes should be complied with.

5.16 Risk Assessment and Risk Reduction

(a) Risk assessment and related risk reduction should be performed at each phase of a conveyor or conveyor system's life cycle. Examples of risk assessment processes can be found in the following:

- (1) CEMA Technical Report 2015-01
- (2) ASSE Z590.3
- (3) MIL-STD-882

(b) This Standard should be used in the risk assessment process and has evolved from assessment of the hazards and risks associated with conveyors. This Standard also identifies appropriate safeguards to reduce the danger to an acceptable level.

(c) Companies that produce standard products/equipment may conduct a risk assessment analysis for a product group in lieu of each individual standard product shipped out of that product group.

6 SPECIFIC SAFETY STANDARDS³

6.1 Belt Conveyors: Fixed in Place

6.1.1 Safety Considerations

(a) Nip and shear points shall be guarded. Typical locations are

- (1) at terminals, drives, take-ups, pulleys, and snub rollers where the belt changes direction
- (2) where belts wrap around pulleys
- (3) at the discharge end of a belt conveyor
- (4) on transfers and deflectors used with belt conveyors
- (5) at take-ups
- (6) idlers located underneath the skirtboards
- (7) accessible return idlers on the inclined portion of a belt conveyor less than 2.44 m (8 ft) above the working surface
- (8) accessible carrying and return idlers at convex and horizontal curves

(b) It is not the intent of this requirement to provide guarding along the conveyor length where the belt rides on the carrying or return rollers.

(c) Take-up mechanisms may be guarded as an entity by placing standard railings or fencing around the area with suitable warning signs, as an alternative to guarding individual nip and shear points.

(d) On overland conveyors, audible or visual (or both) signalling devices for warning conveyor initiation shall be required only at the transfer, loading, and discharge points or at those points where personnel are normally stationed.

(e) On long overland belt conveyors where a pedestrian overpass or underpass is required, they shall be installed at intervals consistent with usage, normally not to exceed 300 m (1,000 ft).

6.1.2 Operation and Maintenance

(a) Only trained personnel shall track a conveyor belt, which must be done while the conveyor is operating.

(b) The practice of applying a belt dressing or other foreign material to a rotating drive pulley or conveyor belt is hazardous and should be avoided.

(c) The use of portable emergency stop controllers in lieu of permanently installed pull cords, push-button stations, etc., shall be permitted for maintenance personnel who patrol overland conveyors. At those points where

personnel are normally stationed, the conveyors shall be equipped with permanently installed pull cords or similar stop controllers.

6.2 Guarding of Bucket Conveyors

(a) Guards shall be provided at points where personnel could come in contact with cables, chains, belts, and runways of exposed bucket conveyors.

(b) Inspection or maintenance doors, or both, should include signs warning of possible danger if opened or removed while the conveyor is in operation.

6.3 Safety Considerations for Chain Conveyors

(a) Chain conveyors, by necessity, have moving chains that cannot be enclosed without impairing the function. They shall be provided with warning signs or personnel barriers, unless guarded by location.

(b) Where a chain conveyor is raised and lowered as a transfer mechanism, mounted within another conveyor, and where enclosure would impair the function, warning signs or personnel barriers shall be provided, unless guarded by location.

6.4 En Masse Conveyors

6.4.1 Safety Considerations. En masse conveyors are not considered freestanding and are to be braced at intervals indicated by the manufacturer. Eccentric platform loads or other lateral loads may require lateral bracing or other bracing or both.

6.4.2 Guarding. Inspection or maintenance doors, or both, should include signs warning of possible danger if opened or removed while conveyor is in operation.

6.4.3 Operation and Maintenance

(a) Where flight or casing cleaning, or both, are required, they shall be performed by trained personnel, with conveyor power supply locked out. Special attention may be required at feed and discharge points.

(b) When coupling or uncoupling the en masse conveyor line, the line shall be restrained to prevent injury through the uncontrolled travel of the broken line.

6.5 Flight and Apron Conveyors: Bulk Material

6.5.1 Safety Considerations. Inclined apron conveyors shall be equipped with lifting blades when the conveyor inclination exceeds the slide angle of the design material.

6.5.2 Operation and Maintenance. At installation, flight and apron conveyors should be "jogged" or hand run through at least one complete revolution to check design clearances prior to running under automatic power.

Flight and apron conveyors handling sticky materials, which tend to build up, shall be cleaned as often as required for safe operation.

6.6 Inclined Reciprocating Conveyors

(18) 6.6.1 Safety Considerations

(a) Means shall be provided to prevent hazard to personnel in the event of mechanical or electrical failure. Antirunaway, brake, or backstop devices shall be provided, sufficient to stop and hold the carrier and load in the event of mechanical or electrical failure.

(b) Overtravel devices shall be provided where necessary to minimize potential for injury to personnel.

(c) Riding the conveyor shall be forbidden to all personnel. Warning signs to this effect shall be prominently posted at each point of access and operation.

6.6.2 Guarding

(a) The conveyor shall be guarded so as to prevent injury from inadvertent physical contact.

(b) The conveyor housing shall be equipped with doors or an equivalent means at each manual loading and unloading station, arranged so that they can be opened only when the carrier is present at that level and such that the carrier cannot be actuated until they are closed. This requirement is typically satisfied by use of a mechanical locking device, which is actuated by the motion of the carrier, and an electrical switch indicating that the door is closed.

(c) Inclined reciprocating conveyors that automatically receive and discharge material may have interlocked doors as in (b) or, as an alternative, may be guarded by a suitable enclosure extending from the path of the moving carrier.

(d) Where the application requires that personnel walk onto the carrier to load or unload material, the carrier shall be provided with standard railings, snap chains, or equivalent, across the loading/unloading side(s). Snap chains shall be at least 1 m (39 in.) at their lowest point.

(e) Controls shall be installed or located so they cannot be actuated by a person on the carrier.

6.7 Live Roller Conveyors: Belt or Chain Driven

6.7.1 Safety Considerations

(a) Nip points occur between chain and sprockets on chain-driven live roller conveyors.

(b) Nip points can occur between belt and carrier rollers on belt-driven live roller conveyors.

(c) Nip points occur at terminals, drives, take-ups, idlers, and snub rollers where the belt changes direction. A return belt idler does not require guarding.

(d) Nip points occur on transfers and deflectors used with live roller conveyors.

(e) Shear points occur at automatic take-ups; they shall be guarded.

6.7.2 Guarding

(a) On chain-driven live roller conveyors, unless guarded by location or position, the nip point between chains and sprockets shall be enclosed to prevent entry of hands, fingers, or other parts of the body into a point of hazard by reaching through, over, under, or around the guard.

(b) On belt-driven live roller conveyors, nip points between the belt and roller may be considered guarded if the load-carrying rollers are spaced so as to prevent access, if plates or rods are placed between rollers, if pop-out rollers are used as load-carrying rollers, or if other suitable guarding is used, such as guarding by location.

6.8 Mobile Conveyors

6.8.1 Safety Considerations

(a) Mobile conveyors shall be provided with a brake, rail clamp, or other position-locking device for each motion, such as, but not limited to, luffing, slewing, and traversing, where movement would present a hazard.

(b) Limit switches shall be provided on rail-mounted mobile conveyors to limit the travel within design limits. Rail stops shall be provided beyond the design travel limits to physically stop the mobile conveyor in case of overtravel.

(c) Sweeps shall be provided on all rail-mounted mobile conveyors to deflect objects ahead of the nip points between wheels and rails where a hazard to personnel would result without the sweep.

(d) A mobile conveyor shall be designed to be stable against runaway or overturning under normal conditions of operation. Resting a portion of a mobile conveyor on the ground, a pile, or any other support shall not cause instability of the machine.

6.8.2 Guarding

(a) Where power to electrically powered mobile conveyors is provided by trolley or rail, these conductors shall be guarded in such a manner as to prevent accidental contact by personnel.

(b) Access stairways, ladders, and platforms shall be designed and located so as to avoid hazardous shear or nip points between sections of structures that in operation move relative to each other.

6.8.3 Operation and Maintenance

(a) When a mobile conveyor exposed to high wind conditions creates a hazard to personnel, normal operation shall cease, and, if necessary, the conveyor shall be moved to a parking position and secured.

(b) When an operator is required on a mobile conveyor, a platform or cab shall be constructed for his protection. The conveyor shall be designed so that, when the operator is on the platform engaged in the normal performance of his duties, he will be protected from injury.

(c) Where operation is such that there is danger of movement of the mobile conveyor into the stockpile or any other obstacle, a detector shall be provided to stop the conveyor movement.

6.9 Safety Considerations for Portable Conveyors, Extendable Belt Conveyors, and Car Unloaders

(a) The raising and lowering mechanism for the boom of a portable conveyor shall include in its design, or be provided with, a safety device that will hold the boom at any rated angle of inclination.

(b) A powered extendable conveyor shall be equipped with a device located on the outermost boom end that shall stop extension of the conveyor when contact is made with the device as may be required to protect personnel.

(c) An extendable conveyor shall be equipped with momentary contact push buttons without holding circuits to activate powered booms.

(d) Portable conveyors shall be stable when used within the manufacturer's rating so that the conveyor will not topple when in use or when being moved in the manner for which it was intended. When the portable conveyor must be lashed to prevent movement or overturning in high winds, a warning sign indicating the necessity shall be clearly posted.

(e) Guarding by location shall be determined with the boom in its lowest position.

6.10 Safety Considerations for Pusher Bar Conveyors

(a) If a hazard exists where the bar passes through the bed at the discharge end, suitable guards or warnings shall be provided at this point.

(b) Loads on the incline shall have pushers of adequate height above the bed or shall have top-restraining members.

(c) All chains shall be guarded by suitable means, including warning signs, to prevent accidental contact with the moving chain.

(d) In a pusher bar conveyor having a roller bed, where the relationship between the height of the bar and spacing of the rollers creates a hazard, adequate guarding shall be provided.

(e) When a shear point exists between the return pusher bar and a frame member, guarding shall be provided.

(f) When the conveyor is automatically loaded, an automatic spacer shall be provided to ensure feeding the loads ahead of the pusher bars where a hazard to personnel could exist.

(g) When a pusher bar conveyor discharges to another conveyor, means shall be provided to stop the pusher bar conveyor in the event the receiving conveyor cannot accept another load.

6.11 Roller and Wheel Conveyors

6.11.1 Safety Considerations

(a) Unit or package speeds that could create a safety hazard shall be avoided by limiting the length of the pitched run or using speed retarders, brakes, or other means that effectively provide the control needed.

(b) Personnel shall not be allowed to walk or step on free-turning rollers or wheels. Suitable means, such as tread plates, can be used between the rollers as a walking surface for designated operators in the performance of their duties.

6.11.2 Operation and Maintenance. Rollers and wheels shall be free-running to prevent unintentional diverting of units being conveyed when such a diverted unit could create a hazard to personnel.

6.12 Safety Considerations for Screw Conveyors

(a) Except as provided in (b) and (c), screw conveyors shall not be operated unless the conveyor housing completely encloses the conveyor-moving elements and power transmission guards are in place.

(b) If the conveyor must have an open housing as a condition of its use and application, the entire conveyor is then to be guarded by a railing or fence, unless guarded by location.

(c) Feed openings for shovel, front-end loader, or other manual or mechanical equipment shall be constructed in such a way that the conveyor screw is covered by grating. If the nature of the material is such that a grating cannot be used, then the exposed section of the conveyor is to be guarded by a railing, and there shall be warning signs posted.

6.13 Safety Considerations for Shuttle Conveyors, Belt Trippers, and Transfer Cars

(a) These conveyors shall be provided with a brake, rail clamp, or other position-locking device.

(b) Means shall be provided to limit travel. Stops shall be provided beyond the normal travel limits to stop the conveyor in case of overtravel.

(c) When the conveyor and its path are obstructed from view of the controlling operator, the conveyor shall have a device to warn of its movement or provide other means to ensure personnel safety in the area.

(d) Sweeps shall be provided for all moving cars, trippers, or shuttles to deflect objects ahead of pinch points between wheels and rails, where a hazard to personnel would result without the sweep.

(e) Although all nip and shear points shall be guarded, it is not the intent of this requirement to provide guards where the belt rides on the idlers.

(f) Trippers or shuttles may discharge into silo or bunker openings, with or without seals. In either case, openings shall be provided with grating to suit the material being handled, and the width of the openings shall not be large enough to permit personnel to fall through. Where material size requires openings that would permit personnel to fall through, the openings shall be protected by other means.

(g) Where power is electrically provided via trolley or rail, these power conductors shall be guarded in such a manner as to prevent accidental contact by personnel. In explosive areas, explosion-proof equipment and cable reels shall be used instead of trolley and rail.

(h) When a person is required to move with the shuttle, tripper, or transfer car, a workstation shall be provided for his/her protection.

6.14 Skip Hoists: Bulk Materials

6.14.1 Safety Considerations

(a) Limit switches shall be provided to establish travel limits of the skip bucket. Additional switches shall be provided to interrupt the power supply and actuate the hoist brake whenever the skip bucket, through failure of the design travel limit switches or for any other reason, exceeds the design travel limit by a predetermined safe distance.

(b) Slack cable switches shall be provided and so arranged that whenever the skip- or counterweight-hoisting rope develops slack or loses tension due to sticking in the guides, overtravel, or any other reason, power to the drive will be cut off and the brake will be set.

(c) Riding the skip bucket by personnel shall be forbidden.

6.14.2 Guarding

(a) All sheaves shall be fitted with sheave guards to prevent the wire rope from coming off the sheaves under a slack cable or similar condition.

(b) The guarding of the wire rope and drum on the hoist is normally not practical due to fleet angle requirements. If the hoist unit is located in an area that is generally accessible, then a complete wire mesh or similar guard shall be placed around the hoist. This guard is not required when guarded by location.

6.14.3 Operation and Maintenance

(a) The following wearing parts should be regularly and frequently inspected by qualified maintenance personnel and maintained regularly or replaced when the degree of wear indicates possibility of failure before the next inspection:

- (1) brake shoes and operating parts
- (2) hoisting ropes, clamps, and attachments
- (3) sheaves, particularly head sheaves
- (4) tracks, wheels, and mechanisms
- (5) limit switches and slack cable device

(b) Whenever the brake or any parts of the drive train between the brake and drum shaft are being repaired or replaced, the skip bucket and counterweight shall be blocked in their guides.

6.15 Slat Conveyors and Roller Slat Conveyors

6.15.1 Safety Considerations. A slat conveyor can present a shear point when the gap between the slats is great enough to permit access to cross members below the slats. At these points, all members should be a safe distance away from the slats, or a continuous pan under the slats should be provided.

6.15.2 Guarding. A hazard exists at the tail end of a slat conveyor in which the slats are above the center line of the chain. The gap between slats closes when the slats reach the top surface of the conveyor. This area should be guarded. If the material flow enters over the tail sprocket, making guards impractical, a warning sign should identify the hazard.

6.16 Suspended Vertical Tray Conveyors

6.16.1 Safety Considerations

(a) Means shall be provided to sense overloads where these loads could cause failure and injury to personnel.

(b) Automatic loading and unloading devices are recommended to prevent the placing of any parts of the human body into the path of vertically traveling carriers.

6.16.2 Guarding

(a) The conveyor shall be installed in an enclosed shaftway or housing to prevent injury from inadvertent physical contact with moving parts of the equipment. Access doors to the shaftway or housing shall be secured so that only authorized service personnel may enter.

(b) For suspended vertical tray conveyors designed so that the pendant tray, car, or carrier comes to a stop during manual loading or unloading, the conveyor housing should be equipped with interlocked doors or equivalent safety barriers at each manual loading and unloading station. The doors shall be mechanically or electrically interlocked to the operation of the conveyor so that they can be opened only when the pendant tray, car, or carrier has stopped and so that the pendant tray, car, or carrier cannot be moved until they are closed.

(c) Suspended vertical tray conveyors designed to automatically receive and discharge material may have interlocked doors as in (b) or, as an alternative, may be guarded by a suitable enclosure extending on all

sides a safe distance from the path of the moving pendant trays, cars, or carriers.

6.17 Tow Conveyors

6.17.1 Tow Conveyors: In the Floor/Overhead

6.17.1.1 Safety Considerations

(a) A clearance space for personnel shall be provided between the side of a cart, or between any load overhanging the side of a cart, and any fixed or moving object.

(b) The cart path shall be identified by a floor stripe parallel to the cart path, one line on each side, located a safe distance from the edge of the cart or overhanging load.

(c) Where wall openings or other conditions do not permit a safe clearance, the reduced clearance area shall be marked with appropriate warnings.

(d) Where a cart may change its direction without warning, such as switching off the main line into a transfer conveyor or a spur, this area shall be marked with an appropriate warning such as diagonal stripes on the floor within the clearance lines.

(e) Where carts start automatically, a warning is required.

(f) Means shall be provided to allow the operator to disengage the tow pin from the conveyor pusher without being in front of the cart.

6.17.1.2 Guarding

(a) Provisions shall be made to prevent runaway carts from exiting the ramp zone and entering work areas.

(b) Ramps with traffic aisles shall have a barrier of sufficient strength and height to prevent a runaway cart from entering the traffic aisle.

(c) Ramps without traffic aisles shall have warning signs to warn personnel not to enter.

(d) Means shall be provided to maintain the stopped position of a ramp conveyor or carts under maximum rated load condition.

(e) Where there is a projection above the floor, the projection and adjacent area shall be identified by appropriate diagonal stripes, warning signs, or both. This identification shall particularly apply to devices that project intermittently at unpredictable times.

(18) 6.17.2 Tow Conveyors: Public Use Intended

6.17.2.1 Safety Considerations

(a) Means shall be provided to sense overloads where these loads could cause injury.

(b) Loading and unloading areas shall be provided with means to detect personnel on or in unauthorized proximity to the conveyor and automatically stop or prevent motion.

(c) Means shall be provided to physically restrict people from the path of the towed vehicle.

(d) Riding or walking on the conveyor or towed vehicle shall be forbidden. Warning signs to this effect shall be prominently posted at each point of access and control station.

(e) Where possible, means should be provided to physically restrict the entry of unauthorized carts into the conveyor.

(f) Means shall be provided to restrict the entry of unauthorized carts into the area where the conveyor is located. At a minimum, warning signs shall be prominently posted at the loading point of each conveyor indicating that only carts specifically designed for use on the conveyor are allowed.

6.17.2.2 Guarding. Where a parted chain, cable, belt, tow pin, or other linkage would permit a runaway condition on an incline or decline, means shall be provided to prevent runaway carts from exiting the ramp zone and entering pedestrian areas.

6.18 Trolley Conveyors and Power and Free Conveyors

6.18.1 Safety Considerations

(a) In areas where the parted chain, cable, or other linkage would permit a runaway condition on an inclined or declined section, and where personnel are present, antirunaway devices shall be provided. The conveyor path may be arranged so that travel of the uncontrolled conveyor will be arrested before it enters an area where personnel are present.

(b) In areas where personnel perform work on the load of a moving conveyor, and guards would impair the workers' performance, the load shall be cradled, hooked, bolted, or otherwise attached to the carrier.

6.18.2 Guarding

(a) Nip points occur at traction wheels, sprockets, caterpillar drives, and roller turns and shall be guarded unless guarded by location.

(b) The telltale effect of the moving conveyor components serves as a warning device and permits unguarded nip or shear points at heights of less than 2.44 m (8 ft).

(c) Automatic stops or closures shall prevent a trolley or trolleys from moving off the track during the portion of a cycle when any track end is not aligned with its mating member.

(d) Hoisting equipment for lift sections and/or drop sections shall stop or control the vertical motion in the event of power failure.

(e) On inclined or declined conveyors or sections, where personnel are present and there may be an occurrence of uncontrolled movement of a free trolley, arresting devices shall be provided. A rigid pusher dog on the power chain with positive carrier engagement shall be considered an acceptable means, or the conveyor path may be arranged so that travel of the uncontrolled free

trolley, carrier, or load, or combination thereof, will be arrested before it enters the personnel area.

(f) Guards shall be provided to restrict unauthorized personnel from entering hazardous loading, unloading, and transfer areas. When guarding is not feasible, clear and legible warnings shall be provided.

(g) Access to lift or drop sections shall be guarded to prevent unauthorized personnel from entering the area. Warning signs shall be posted where guarding is not feasible, unless access to lift or drop sections is guarded by location.

(h) Where conveyors are located above personnel and the possibility exists that the transported product may fall off from any cause, guards (spill guards) shall be provided.

6.19 Vertical Articulated Conveyors

6.19.1 Safety Considerations

(a) The control system shall include means to prevent jamming or spilling objects if the absence of such controls could produce a hazard to personnel.

(b) Means shall be provided to stop the conveyor in the event a jam occurs where injury to personnel would otherwise result.

6.19.2 Guarding

(a) The conveyor shall be enclosed to prevent injury from inadvertent physical contact with the moving parts of the equipment.

(b) The entry and exit openings in the enclosure shall be guarded by extending the enclosure side guards a safe distance from the path of the vertically moving carrier. A top cover shall be provided to form a tunnel, if practical.

6.20 Vertical Chain-Opposed Shelf Type Conveyors

6.20.1 Safety Considerations. Overload devices shall be furnished to stop the conveyor in the event a jam occurs where injury to personnel would otherwise result.

6.20.2 Guarding

(a) The conveyor shall be housed so as to prevent injury from inadvertent physical contact with the moving parts of the equipment.

(b) The conveyor housing shall be equipped with doors or an equivalent means at each manual loading and unloading station, arranged so that they can be opened only when the carrier is present at that level and such that the carrier cannot be actuated until they are closed. This requirement is typically satisfied by use of a mechanical locking device, which is actuated by the motion of the carrier, and an electrical switch indicating that the door is closed.

(c) Vertical chain-opposed shelf conveyors that automatically receive and discharge material may have interlocked doors as in (b) or, as an alternative, be guarded by a suitable enclosure extending from the path of the moving carrier platform.

6.21 Vertical Reciprocating Conveyors

6.21.1 Safety Considerations

(18)

(a) Means shall be provided to prevent hazard to personnel in the event of mechanical or electrical failure. Antirunaway, brake, or backstop devices shall be provided, sufficient to stop and hold the carrier and load in the event of mechanical or electrical failure. (See [Mandatory Appendix I](#).)

(b) Overtravel device(s) shall be provided where necessary to minimize potential for injury to personnel.

(c) Riding the conveyor shall be forbidden to all personnel. Warning signs to this effect shall be prominently posted at each point of access and operation.

6.21.2 Guarding

(a) The conveyor shall be guarded so as to prevent injury from inadvertent physical contact.

(b) The conveyor housing shall be equipped with doors or an equivalent means at each manual loading and unloading station, arranged so that they can be opened only when the carrier is present at that level and such that the carrier cannot be actuated until they are closed. This requirement is typically satisfied by use of a mechanical locking device, which is actuated by the motion of the carrier, and an electrical switch indicating that the door is closed.

(c) Vertical reciprocating conveyors designed to automatically receive and discharge material may have interlocked doors as in (b) or, as an alternative, be guarded by a suitable enclosure extending from the path of the moving carrier.

(d) Where the application requires that personnel walk onto the carrier to load or unload material, the carriers shall be provided with standard railings, snap chains, or equivalent across the loading/unloading side(s). Snap chains shall be at least 1 m (39 in.) at their lowest point.

(e) Controls shall be installed or located so they cannot be actuated by a person on the carrier.

6.22 Material Encapsulating Conveyors

6.22.1 Safety Considerations

(a) The family of belt conveyors that encapsulate the product on the carrying side and fold or roll the belt on the return side have in-running nip points at the belt/roller interface. These belt conveyors are known by trade names such as pipe, tube, square belt, multifold, etc.

(b) The nip points occur where the belt exerts a force on the containment rolls and may cause entrapment because of the inability to move or lift the belt off the idler roll.

(c) Conveyors of these types must be reviewed to determine if warnings, controls, or guarding are required.

6.22.2 Guarding. On material encapsulating conveyors, unless guarded by location or position, guarding shall be provided to prevent inadvertent contact where the belt and encapsulating rolls create nip points.

6.22.3 Operation and Maintenance

(a) Only trained personnel shall track an encapsulating conveyor belt, which must be done while the conveyor is operating.

(b) Emergency pull cords shall be located along the accessible side(s) of the entire conveyor.

(18) 6.23 Mobile Hopper Railcar/Hopper Bottom Truck Unloader Conveyor

These mobile unloaders are for bulk products. They are identified by a low-profile tail-end loading section that transitions to an incline. At the transition, they utilize hold-down wheels riding on the belt's carrying side. Manually operated gates under the railcar or truck that are used to regulate the flow of material onto the conveyor must often be adjusted while the belt is moving.

The combination of the low-profile conveyor belt and the hold-down mechanism(s) on the belt results in a dangerous condition. Further, because of the low-profile belt, an operator working alongside the conveyor to adjust the railcar or truck gate(s) risks becoming entangled with the belt and/or the hold-down mechanism(s).

For this reason, a risk assessment should be performed to determine the best method to address these specific hazards. The risk assessment should also identify any required warnings or specialized training. A site-specific risk assessment should also be performed to identify local hazardous conditions. See [para. 5.16](#).

Where manual gate adjustment exposes an operator to the hold-down mechanism or conveyor, the low-profile loading section shall be guarded to prevent operators

from crossing or falling on the belt. Where it is not feasible to guard, warning signs shall be posted.

6.24 Electrified Monorail Conveyors Used for Assembly/Inspection/Testing Processes (18)

6.24.1 Safety Considerations

(a) Where, as in the automotive and aircraft industries, electrified monorail conveyors are used in assembly, inspection, and testing operations that necessitate the conveying and positioning of the conveyor, its carrier, and the product above personnel, the following requirements apply:

(1) Risk assessment and related risk reduction per [para. 5.16](#) shall be mandatory.

(2) Mechanical load-bearing components coupling the trolley and carrier shall be designed with an allowable stress not to exceed 20% of the minimum ultimate strength of the material (5:1 safety factor).

(3) Carrier positioning mechanisms/hoists shall incorporate sufficient redundancy or safety devices to ensure that a single-point component failure will not result in uncontrolled carrier descent.

(b) Overtravel device(s) shall be provided in any case in which overtravel could cause injury to a person or serious damage to the carrier or trolley.

(c) Where carrier instability could create a hazard, means shall be provided for fore/aft and side-to-side stabilization.

(d) Means shall be provided to prevent hazard to personnel in the event of a power failure.

6.24.2 Guarding. The conveyor shall be guarded so as to prevent injury from inadvertent contact with the moving parts of the equipment.

6.24.3 Operation and Maintenance. Where a safeguard could be compromised by long-term use, the integrity of the safeguards incorporated in the conveyor as a result of the risk-reduction effort [see [para. 6.24.1\(a\)\(1\)](#)] shall be ensured by utilization of computer supervision or scheduled inspections.

MANDATORY APPENDIX I

SPECIFICATIONS FOR DESIGN, INSTALLATION, COMMISSIONING, AND PERIODIC INSPECTION OF VERTICAL RECIPROCATING CONVEYORS

I-1 GENERAL

This Appendix is to be used in conjunction with [sections 1 through 5](#) and [para. 6.21](#). This Appendix covers the specifications for design, installation, commissioning, and periodic inspection of vertical reciprocating conveyors (VRCs) and should be used by equipment designers, manufacturers, suppliers, installers, end users, inspectors, and any other authority having jurisdiction (AHJ).

(a) *Scope.* This Appendix only applies to vertical reciprocating conveyors and inclined reciprocating conveyors as defined in ASME B20.1.

(b) *Form and Arrangement.* This Appendix addresses the details of the unique characteristics of VRCs. VRCs are required by code to conform to all the performance requirements for conveyors. Where performance criteria are specified in [sections 1 through 6](#), this Appendix provides specific design details that ensure compliance with the performance requirements.

(c) *Special Concerns.* This Appendix permits local, state, or federal inspectors to properly distinguish and apply the correct standard.¹ VRCs are conveyors as defined by ASME B20.1. VRCs are not elevators, dumbwaiters, dumbwaiters with automatic transfer devices, or material lifts, which are defined by ASME A17.1/CSA B44. The scope of ASME A17.1/CSA B44 excludes conveyors. The scope of ASME B20.1 excludes elevators, dumbwaiters, dumbwaiters with automatic transfer devices, and material lifts. For more information on how to identify a VRC versus an elevator and the appropriate standard to apply, refer to the white paper authored jointly by the A17 and B20 Committees, which is available on the ASME website under the B20 Committee Page at <http://cstools.asme.org>.

I-2 APPLICATION AND PURPOSE

VRCs are designed only to raise and lower material(s) between two or more landings, including mezzanines and elevated work platforms. They can be installed inside or outside a building. They can be manually loaded or

unloaded at any landing, or they can receive or discharge a load automatically. Riders are not allowed on VRCs.

I-3 DESIGN SPECIFICATIONS

I-3.1 Typical VRC Configurations

(a) *Cantilever Design.* The carrier moves vertically in front of two guide columns. See [Figure I-3.1-1](#).

(b) *Straddle Design.* The carrier moves vertically between two guide columns. See [Figure I-3.1-2](#).

(c) *Four-Post Design.* The carrier moves vertically between four guide columns. See [Figure I-3.1-3](#).

I-3.2 Rated Capacity

The rated capacity is the maximum payload that the VRC is designed to carry.

I-3.3 Guarding Onboard Carrier

(18)

Means for guarding the onboard carrier shall include the following, at minimum:

(a) handrails nominally 1 067 mm (42 in.) high and equipped with a midrail

(b) kick plates 102 mm (4 in.) high on the nonoperating sides of the carrier

(c) a snap chain, or equivalent, that is a minimum of 991 mm (39 in.) high at its lowest point, mounted across the loading or operating side(s)

I-3.4 Controls

Operator controls should be of the press-and-release/momentary-contact type. When actuated, the VRC will operate and continue to operate until stopped by another control device. Each control station shall include an emergency stop device that deactivates all powered functions. All controls shall be protected from inadvertent operation, except the emergency stop (e-stop). All controls shall be located so they are not accessible from the carrier. In automated systems, the control system may be operated by a computer or other programmable logic devices.

¹For general information about VRCs, refer to *Application Guidelines for Vertical Reciprocating Conveyors* (available from CSS).

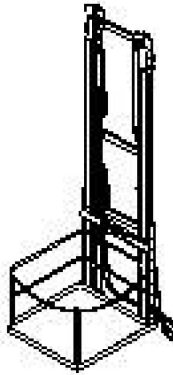
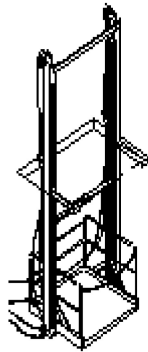
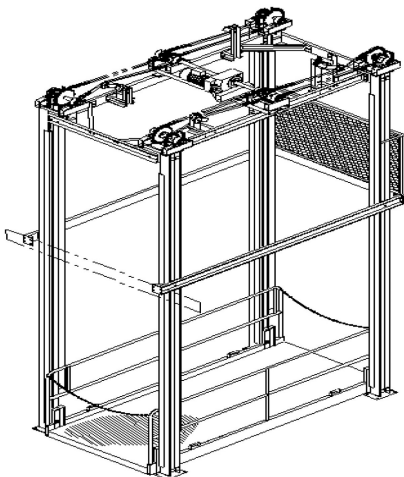
Figure I-3.1-1 Cantilever Design**Figure I-3.1-2 Straddle Design****Figure I-3.1-3 Four-Post Design****I-3.5 Drive Types**

(18)

I-3.5.1 Hydraulically Driven. Where a hydraulic cylinder(s) or ram(s) acts to raise and lower the carrier, lowering of the carrier may be a function of gravity when the holding valve is opened, allowing hydraulic fluid to drain back to the reservoir. The lowering speed shall be controlled by a pressure-compensated flow control valve. The hydraulic cylinder(s) or ram(s) shall be fitted at the pressure port with an excess flow protector. The hydraulic circuit shall prevent carrier movement if the power is removed.

Where the hydraulic cylinder(s) or ram(s) is connected using flexible lifting means such as chain(s), cable(s), or belt(s) to suspend the carrier, a mechanical antirunaway device as defined in [para. 6.21.1\(a\)](#) shall be required to be installed on the carrier to avert freefall in case of failure of the suspension means.

Where the hydraulic cylinder(s) or ram(s) is connected directly to the carrier such that the vertical travel is a 1:1 ratio to the cylinder(s) or ram(s) travel, a carrier-mounted mechanical antirunaway device as described above is not required.

I-3.5.2 Mechanically Driven. Where an electric motor with fail-to-safe brake and a geared reduction acts to raise and lower the carrier and where the carrier is suspended by a flexible lifting means such as chain(s), cable(s), or belt(s), a mechanical antirunaway device as defined in [para. 6.21.1\(a\)](#) shall be required to be installed on the carrier to avert freefall in case of failure of the suspension means.

I-3.6 Running Clearance

(18)

Running clearance between the carrier operating sides and adjacent landings should be 25 mm (1 in.) or less.

I-3.7 Roll-Off Panel

A roll-off panel should be provided on upper levels where a carrier operating end is opposite the floor landing. All open sides of carriers need to be protected from inadvertent roll-off of loads while transferring loads on or off the carrier.

I-3.8 Electrical Codes

All electrical devices shall be installed in accordance with the latest edition of NFPA 70 or NFPA 79.

I-3.9 Gates and Enclosures

(18)

As defined in [para. 6.21.2\(a\)](#), VRC installations shall be guarded to prevent injury from inadvertent contact with any moving component or the load(s) that may be on the carrier. All doors or gates at landings shall be interlocked, such that doors or gates can only be opened at the level where the carriage is present. The interlocking system

Figure I-3.9.2-1 Single-Swing Hinged Gate

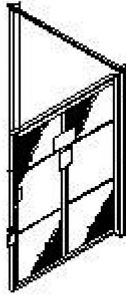

shall require all doors and gates to be closed before the carrier can move to another level. All gates and enclosures must be able to withstand a minimum of 890 N (200 lbf) applied laterally without deflecting into the path of the moving carrier and without permanent deformation. All gates and enclosures shall be composed of material that will reject a 51-mm (2-in.) ball. Enclosures shall be a minimum of 2 438 mm (96 in.) high at each floor level. If the ceiling height is less than 2 438 mm (96 in.), the vertical space should be filled.

I-3.9.1 Landing Gate Requirements. Gates shall be a minimum of 1 829 mm (72 in.) high at each floor level with the exception of the uppermost landing where the gate may be reduced to 1 067 mm (42 in.). Manually actuated gates shall require no more than 222 N (50 lbf) to open or close.

I-3.9.2 Typical Landing Gate Configurations

- (a) *Single-Swing Hinged Gate.* Hinges on one side. See Figure I-3.9.2-1.
- (b) *Biparting, Double-Swing Hinged Gates.* Gate hinges on each side with latches in the center. See Figure I-3.9.2-2.
- (c) *Vertical Rising Gate.* Single- and double-panel gate closes to the floor and opens in the upward direction. Powered gates shall have a photo eye or other type of

Figure I-3.9.2-2 Biparting, Double-Swing Hinged Gates

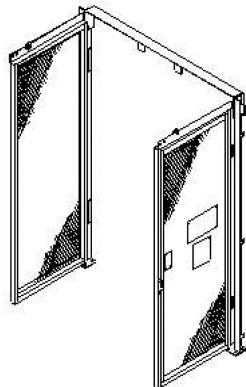

sensor to prevent the gate from lowering unless the area is clear of obstructions, or the lowest edge of powered gates shall be equipped with a touch-sensitive edge that will stop the gate from lowering when it makes contact with an obstruction. See Figure I-3.9.2-3.

(d) *Horizontal Sliding Gate.* Single- or double-panel gate operates in the horizontal direction. See Figure I-3.9.2-4.

(e) *Roll-Up Type Door (Gate).* Door (gate) may be fabricated from steel, fiberglass, or material of similar rigidity. It may be of the manual or powered type. Powered gates shall have a photo eye or other type of sensor to prevent the gate from lowering unless the area is clear of obstructions, or the lowest edge of powered gates shall be equipped with a touch-sensitive edge that will stop the gate from lowering when it makes contact with an obstruction. See Figure I-3.9.2-5.

I-4 MARKINGS AND SIGNAGE

I-4.1 Manufacturer’s Nameplate

VRCs shall be provided with a manufacturer’s nameplate that includes the name of the manufacturer, model number, and serial number. The nameplate shall be durable, corrosion resistant, and permanently secured in a prominent place for inspection.

I-4.2 Precautionary Labeling

(18)

VRCs shall be provided with precautionary labels that are in accordance with NEMA Z535.4.² The minimum labeling shall indicate the following degree or level of hazard seriousness:

- (a) electrical — danger
- (b) top of carrier/carriage — warning
- (c) under carrier/carriage — danger

I-5 MAINTENANCE

I-5.1 Maintenance Instructions

Only authorized personnel should perform inspection, maintenance, and service procedures.

I-5.2 Safe Blocking Instructions

All work should be done with the carrier fully lowered. Where the carrier must be raised, it is to be secured in place per the manufacturer’s instructions.

I-5.3 Control of Hazardous Energy

At a minimum, follow OSHA lockout/tagout procedures (29 CFR 1910.147) for the control of hazardous energy before performing service or maintenance.

² Sample labels are illustrated in *Application Guidelines for Vertical Reciprocating Conveyors* (available from CSS).