

---

**Standard Method of Test for**

**Moisture–Density Relations of Soils  
Using a 4.54-kg (10-lb) Rammer and  
a 457-mm (18-in.) Drop**

---

**AASHTO Designation: T 180-19**

**Technical Subcommittee: 1b, Geotechnical Exploration,  
Instrumentation, Stabilization, and Field Testing**

**Release: Group 3 (July)**



**American Association of State Highway and Transportation Officials  
444 North Capitol Street N.W., Suite 249  
Washington, D.C. 20001**

---

## Standard Method of Test for

# Moisture–Density Relations of Soils Using a 4.54-kg (10-lb) Rammer and a 457-mm (18-in.) Drop

AASHTO Designation: T 180-19



Technical Subcommittee: 1b, Geotechnical Exploration,  
Instrumentation, Stabilization, and Field Testing

Release: Group 3 (July)

---

## 1. SCOPE

- 1.1. This method of test is intended for determining the relationship between the moisture content and density of soils when compacted in a given mold of a given size with a 4.54-kg (10-lb) rammer dropped from a height of 457 mm (18 in.). Four alternate procedures are provided as follows:
- *Method A*—A 101.60-mm (4-in.) mold: Soil material passing a 4.75-mm (No. 4) sieve (see Sections 4 and 5);
  - *Method B*—A 152.40-mm (6-in.) mold: Soil material passing a 4.75-mm (No. 4) sieve (see Sections 6 and 7);
  - *Method C*—A 101.60-mm (4-in.) mold: Soil material passing a 19.0-mm (0.75-in.) sieve (see Sections 8 and 9); or
  - *Method D*—A 152.40-mm (6-in.) mold: Soil material passing a 19.0-mm (0.75-in.) sieve (see Sections 10 and 11).
- 1.2. The method to be used should be indicated in the specifications for the material being tested. If no method is specified, the provisions of Method A shall govern.
- 1.3. This test method applies to soil mixtures that have 40 percent or less retained on the 4.75-mm (No. 4) sieve, when Method A or B is used and 30 percent or less retained on the 19.0-mm (0.75-in.) sieve, when Method C or D is used. Material retained on these sieves shall be defined as oversize particles (coarse particles).
- 1.4. If the test specimen contains oversized particles, dry density and moisture corrections must be made in accordance with Annex A1. The person or agency specifying this method may specify a minimum percentage of oversized particles above which a correction must be applied. If no minimum percentage is specified, correction for the oversized particles shall be applied to material containing more than 5 percent by weight of oversized particles.
- 1.5. If the specified oversized particle maximum percentage is exceeded, other methods of compaction control must be used.
- Note 1**—One method for the design and control of the compaction of such soils is to use a test fill to determine the required degree of compaction and a method to obtain that compaction. Then use a method specification to control the compaction by specifying the type and size of compaction equipment, the lift thickness, and the number of passes.

- 1.6. The following applies to all specified limits in this standard: For the purposes of determining conformance with these specifications, an observed value or a calculated value shall be rounded off “to the nearest unit” in the last right-hand place of figures used in expressing the limiting value, in accordance with ASTM E29.
- 1.7. The values stated in SI units are to be regarded as the standard.

---

## 2. REFERENCED DOCUMENTS

- 2.1. *AASHTO Standards:*
- M 231, Weighing Devices Used in the Testing of Materials
  - R 76, Reducing Samples of Aggregate to Testing Size
  - T 19M/T 19, Bulk Density (“Unit Weight”) and Voids in Aggregate
  - T 85, Specific Gravity and Absorption of Coarse Aggregate
  - T 217, Determination of Moisture in Soils by Means of Calcium Carbide Gas Pressure Moisture Tester
  - T 255, Total Evaporable Moisture Content of Aggregate by Drying
  - T 265, Laboratory Determination of Moisture Content of Soils
  - T 310, In-Place Density and Moisture Content of Soil and Soil–Aggregate by Nuclear Methods (Shallow Depth)
- 2.2. *ASTM Standards:*
- D2168, Standard Practices for Calibration of Laboratory Mechanical-Rammer Soil Compactors
  - E11, Standard Specification for Woven Wire Test Sieve Cloth and Test Sieves
  - E29, Standard Practice for Using Significant Digits in Test Data to Determine Conformance with Specifications

---

## 3. APPARATUS

- 3.1. *Mold Assembly (Mold, Collar, and Baseplate)*—Molds shall be solid-wall, metal cylinders manufactured with dimensions and capacities shown in Sections 3.1.1 and 3.1.2 and in Figures 1 and 2 below. They shall have a detachable collar approximately 60 mm (2.375 in.) in height, to permit preparation of compacted specimens of soil–water mixtures of the desired height and volume. The mold and collar shall be so constructed that it can be fastened firmly to a detachable base plate made of the same material (Note 2). The base plate shall be plane to 0.13 mm (0.005 in.) as shown in Figures 1 and 2.
- Note 2**—Alternate types of mold assemblies with volumes as stipulated herein may be used, provided the test results are correlated with those of the solid-wall mold on several soil types and the same moisture–density results are obtained. Records of such correlation shall be maintained and readily available for inspection when alternate types of molds are used.
- 3.1.1. Molds having a volume of  $0.000943 \pm 0.000014 \text{ m}^3$  ( $0.0333 \pm 0.0005 \text{ ft}^3$ ) shall have an inside diameter of  $101.60 \pm 0.40 \text{ mm}$  ( $4.000 \pm 0.016 \text{ in.}$ ) and a height of  $116.40 \pm 0.50 \text{ mm}$  ( $4.584 \pm 0.018 \text{ in.}$ ) (Figure 1). Determine mold volume in accordance with the “Calibration of Measure” section of T 19M/T 19 for Unit Mass of Aggregate.
- 3.1.2. Molds having a volume of  $0.002124 \pm 0.000025 \text{ m}^3$  ( $0.0750 \pm 0.0009 \text{ ft}^3$ ) shall have an inside diameter of  $152.40 \pm 0.70 \text{ mm}$  ( $6.000 \pm 0.026 \text{ in.}$ ) and a height of  $116.40 \pm 0.50 \text{ mm}$  ( $4.584 \pm 0.018 \text{ in.}$ ) (Figure 2). Determine mold volume in accordance with the “Calibration of Measure” section of T 19M/T 19 for Unit Mass of Aggregate.

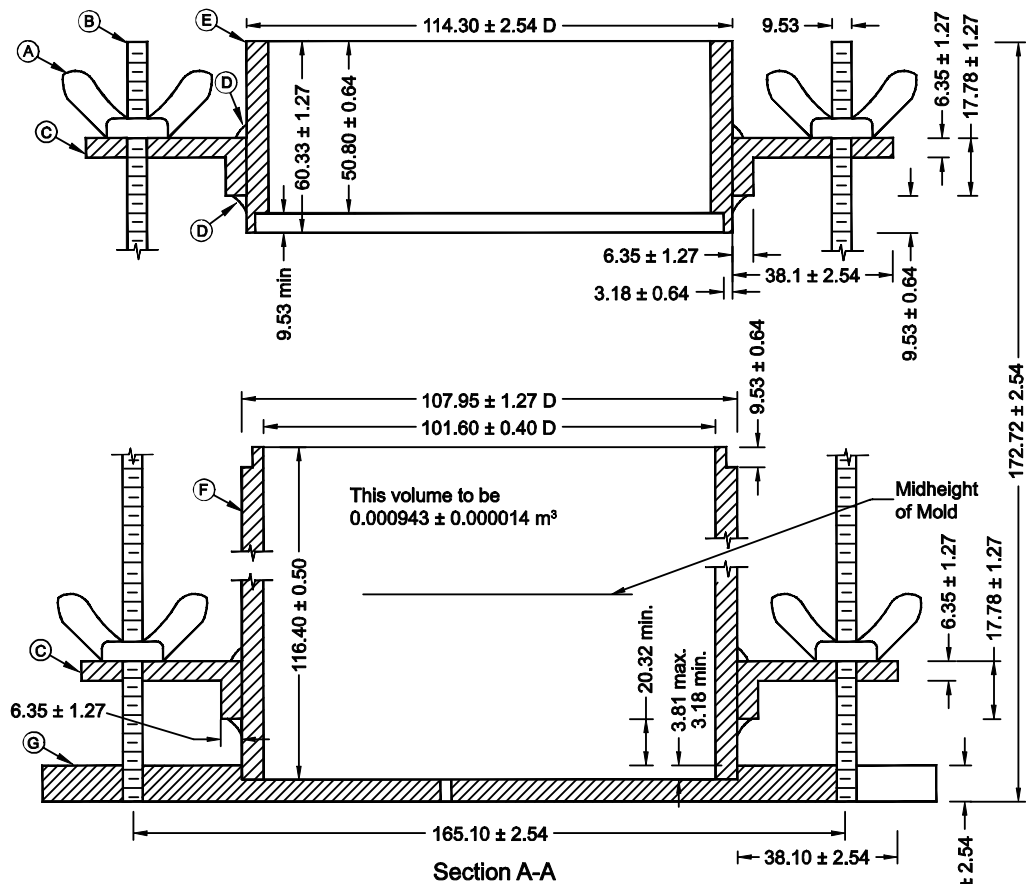

- A Wing Nut (4)
- B Stud (2)
- C Hanger (4)
- D Weld (Top and Bottom of Each Hanger)
- E Collar (1)
- F Mold (1)
- G Base Plate (1)

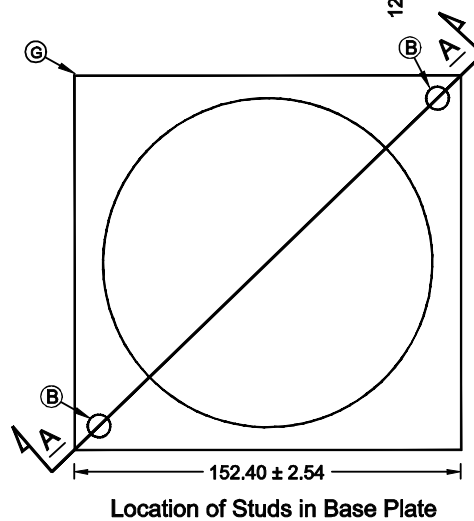

- Notes:
1. All dimensions shown in millimeters unless otherwise noted.
  2. Hanger on the mold portion only cannot extend above the midheight line.
  3. Figure 1 is to be used for all compaction molds purchased after the publication of the 21st edition (HM-21).
  4. Not to scale.

**Figure 1**—Cylindrical Mold and Base Plate (101.60-mm Mold)

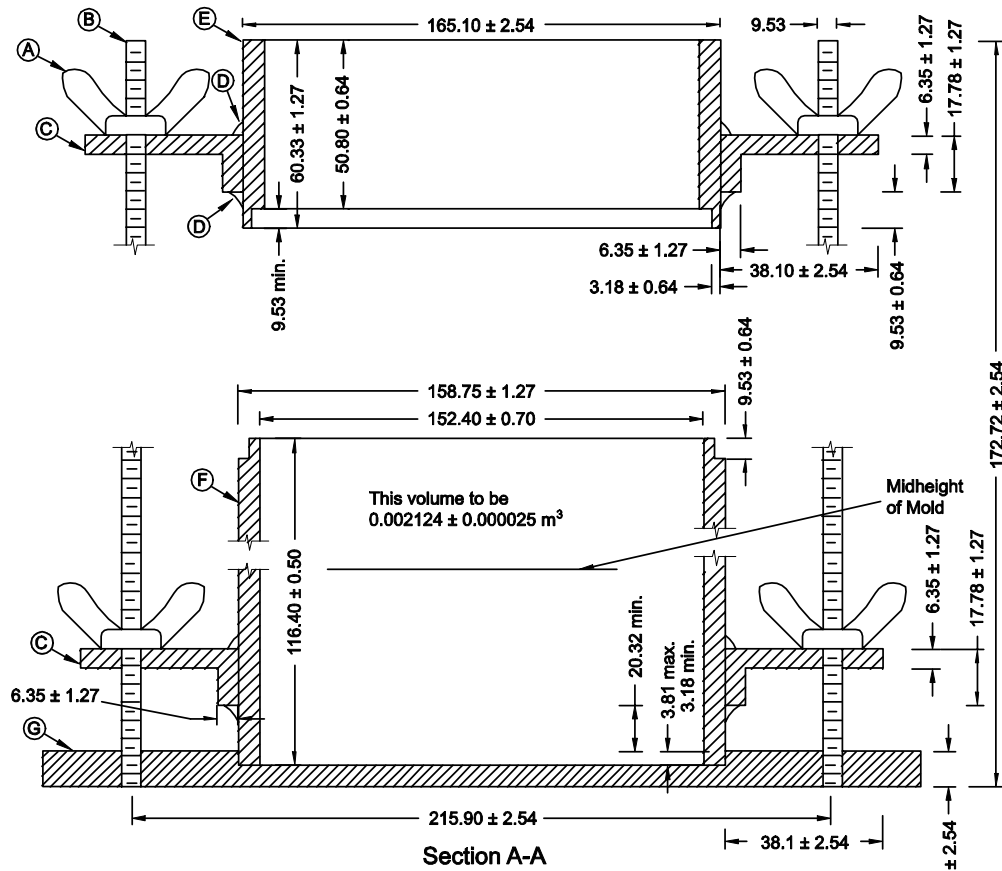

- (A) Wing Nut (4)
- (B) Stud (2)
- (C) Hanger (4)
- (D) Weld (top and bottom of each hanger)
- (E) Collar (1)
- (F) Mold (1)
- (G) Base Plate (1)

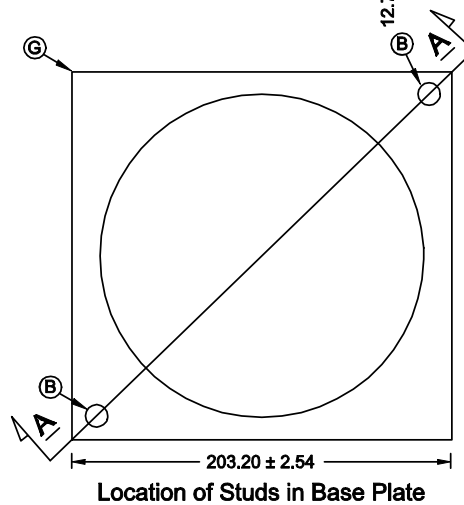

- Notes:
1. All dimensions are shown in millimeters unless otherwise noted.
  2. Hanger on the mold portion only cannot extend above the midheight line.
  3. Figure 2 is to be used for all compaction molds purchased after the publication of the 21st edition (HM-21).
  4. Not to scale.

**Figure 2**—Cylindrical Mold and Base Plate (152.40-mm Mold)

**Table 1**—Dimensional Equivalents for Figure 1

mm	in.	mm	in.	mm	in.
3.18 ± 0.64	0.125 ± 0.025	17.78 ± 1.27	0.700 ± 0.050	107.95 ± 1.27	4.250 ± 0.050
3.81	0.150	20.32	0.800	114.30 ± 2.54	4.500 ± 0.100
6.35 ± 1.27	0.250 ± 0.050	38.10 ± 2.54	1.500 ± 0.100	116.43 ± 0.13	4.584 ± 0.005
7.62	0.300	50.80 ± 0.64	2.000 ± 0.025	152.40 ± 2.54	6.000 ± 0.100
9.53 ± 0.64	0.375 ± 0.025	60.33 ± 1.27	2.375 ± 0.050	165.10 ± 2.54	6.500 ± 0.100
12.70 ± 2.54	0.500 ± 0.100	101.60 ± 0.41	4.000 ± 0.016	172.72 ± 2.54	6.800 ± 0.100
0.000943 ± 0.000009 m <sup>3</sup>		0.0333 ± 0.0005 ft <sup>3</sup>			

**Table 2**—Dimensional Equivalents for Figure 2

mm	in.	mm	in.	mm	in.
3.18 ± 0.64	0.125 ± 0.025	17.78 ± 1.27	0.700 ± 0.050	152.40 ± 0.66	6.000 ± 0.026
3.81	0.150	20.32	0.800	158.75 ± 1.27	6.250 ± 0.050
6.35 ± 1.27	0.250 ± 0.050	38.10 ± 2.54	1.500 ± 0.100	165.10 ± 2.54	6.500 ± 0.100
7.62	0.300	50.80 ± 0.64	2.000 ± 0.025	172.72 ± 2.54	6.800 ± 0.100
9.53 ± 0.64	0.375 ± 0.025	60.33 ± 1.27	2.375 ± 0.050	203.23 ± 2.54	8.000 ± 0.100
12.70 ± 2.54	0.500 ± 0.100	116.43 ± 0.13	4.584 ± 0.005	215.90 ± 2.54	8.500 ± 0.100
0.002124 ± 0.000025 m <sup>3</sup>		0.0750 ± 0.0009 ft <sup>3</sup>			

### 3.2. *Rammer:*

3.2.1. *Manually Operated*—Metal rammer with a mass of 4.536 ± 0.009 kg (10.00 ± 0.02 lb) (Note 3) and having a flat circular face of 50.80 mm (2.000 in.) diameter with a manufacturing tolerance of ±0.25 mm (±0.01 in.). The in-service diameter of the flat circular face shall be not less than 50.42 mm (1.985 in.). The rammer shall be equipped with a suitable guide sleeve to control the height of drop to a free fall 457 ± 2 mm (18.00 ± 0.06 in.) above the elevation of the soil. The guide sleeve shall have at least four vent holes, no smaller than 9.5-mm (0.375-in.) diameter, spaced approximately 90 degrees (1.57 rad) apart from each end, and shall provide sufficient clearance so the free fall of the rammer shaft and head is unrestricted.

3.2.2. *Mechanically Operated*—A metal rammer that is equipped with a device to control the height of drop to a free fall of 457 ± 2 mm (18.00 ± 0.06 in.) above the elevation of the soil, and uniformly distributes such drops to the soil surface (Note 3). The rammer shall have a mass of 4.536 ± 0.009 kg (10.00 ± 0.02 lb) (Note 2) and have a flat circular face of 50.80 mm (2.000 in.) diameter with a manufacturing tolerance of ±0.25 mm (±0.01 in.). The in-service diameter of the flat circular face shall be not less than 50.42 mm (1.985 in.). The mechanical rammer shall be calibrated by ASTM D2168 to give the same moisture–density results as with a manually operated rammer.

**Note 3**—The mechanical rammer apparatus shall be calibrated with several soil types and the mass of the rammer adjusted, if necessary, to give the same moisture–density results as with the manually operated rammer.

It may be impractical to adjust the mechanical apparatus so the free fall is 457 mm (18 in.) each time the rammer is dropped, as with the manually operated rammer. To make the adjustment of free fall, the portion of loose soil to receive the initial blow should be slightly compressed with the rammer to establish the point of impact from which the 457-mm (18-in.) drop is determined; subsequent blows on the layer of soil being compacted may all be applied by dropping the rammer from a height of 457 mm (18 in.) above the initial-setting elevation, or when the mechanical apparatus is designed with a height adjustment for each blow, all subsequent blows should have a rammer free fall of 457 mm (18 in.) measured from the elevation of the soil as compacted by the previous blow. A more detailed calibration procedure for laboratory mechanical rammer soil compactors can be found in ASTM D2168.

- 3.2.3. *Rammer Face*—The circular face rammer shall be used but a sector face rammer may be used as an alternative provided that the report shall indicate type of face used other than the 50.8-mm (2-in.) circular face, and that the sector face rammer shall have an area equal to that of the circular face rammer. The in-service area of sector face rammers shall be standardized and yield a surface area within 1.5 percent of the area of the 50.8-mm (2-in.) circular face rammer.
- 3.3. *Sample Extruder (for Solid-Walled Molds Only)*—A jack, lever, frame, or other device adapted for the purpose of extruding compacted specimen from the mold.
- 3.4. *Balances and Scales*—A balance or scale conforming to the requirements of M 231, Class G 5. Also, a balance conforming to the requirements of M 231, Class G 2.  
**Note 4**—The capacity of the metric balance or scale should be approximately 11.5 kg (25 lb) when used to determine the mass of the 152-mm (6-in.) mold and compacted, moist soil; however, when the 102-mm (4-in.) mold is used, a balance or scale of lesser capacity than 11.5 kg may be used, if the sensitivity and readability are 1 g.
- 3.5. *Drying Oven*—A thermostatically controlled drying oven capable of maintaining a temperature of  $110 \pm 5^\circ\text{C}$  ( $230 \pm 9^\circ\text{F}$ ) for drying moisture samples.
- 3.6. *Straightedge*—A hardened steel straightedge at least 250 mm (10 in.) in length. It shall have one beveled edge, and at least one longitudinal surface (used for final trimming) shall be plane within 0.1 percent of the length within the portion used for trimming the soil (Note 5).  
**Note 5**—The beveled edge may be used for final trimming if the edge is true within a tolerance of 0.25 mm per 250 mm (0.1 percent) of length; however, with continued use, the cutting edge may become excessively worn and not suitable for trimming the soil to the level of the mold. The straightedge should not be so flexible that trimming the soil surface with the cutting edge will cause a concave soil surface.
- 3.7. *Sieves*—19.0-mm (0.75-in.), and 4.75-mm (No. 4) sieves conforming to the requirements of ASTM E11.
- 3.8. *Mixing Tools*—Miscellaneous tools such as mixing pan, spoon, trowel, spatula, etc., or a suitable mechanical device for thoroughly mixing the sample of soil with increments of water.
- 3.9. *Containers*—Suitable containers made of material resistant to corrosion and not subject to change in mass or disintegration on repeated heating and cooling. Containers shall have close-fitting lids to prevent loss of moisture from samples before initial mass determination and to prevent absorption of moisture from the atmosphere following drying and before final mass determination. One container is needed for each moisture content determination.

---

## METHOD A

---

### 4. SAMPLE

- 4.1. Obtain a representative sample. This sample must be large enough that when the oversized (retained on the 4.75-mm (No. 4) sieve) particles are removed 3 kg (7 lb) or more of the sample remains.
- 4.2. Dry the sample until it becomes friable under a trowel. Drying may be in air or by use of a drying apparatus that is maintained at a temperature not exceeding  $60^\circ\text{C}$  ( $140^\circ\text{F}$ ). Thoroughly break up the aggregation in such a manner as to avoid reducing the natural size of individual particles.

- 4.3. Sieve the soil over the 4.75-mm (No. 4) sieve. When the sample has oversized particles, particles retained on the 4.75-mm (No. 4) sieve, refer to the Annex A1. Reduce the sample, to a mass of 3 kg (7 lb) or more in accordance with R 76.

---

## 5. PROCEDURE

- 5.1. Determine the mass of the mold and base plate to the nearest 1 g (0.005 lb).
- 5.2. Thoroughly mix the selected representative sample with sufficient water to dampen it to approximately four to eight percentage points below optimum moisture content.  
**Note 6**—When developing a compaction curve for free-draining soils, such as uniform sands and gravels, where seepage occurs at the bottom of the mold and base plate, taking a representative moisture content sample from the mixing bowl may be preferred to determine the amount of moisture available for compaction.
- 5.3. Form a specimen by compacting the prepared soil in the 101.60-mm (4-in.) mold assembly in five approximately equal layers to give a total compacted depth of about 125 mm (5 in.). Prior to compaction, place the loose soil into the mold assembly and spread into a layer of uniform thickness. Lightly tamp the soil prior to compaction until it is not in a loose or fluffy state, using either the manual compaction rammer or similar device having a face diameter of approximately 50 mm (2 in.). Following compaction of each of the first four layers, any soil adjacent to the mold walls that has not been compacted or extends above the compacted surface shall be trimmed using a knife or other suitable device, and be evenly distributed on top of the layer. Compact each layer by 25 uniformly distributed blows from the rammer dropping free from a height of 457 mm (18 in.) above the elevation of the soil when a sleeve-type rammer is used, or from 457 mm (18 in.) above the approximate elevation of the soil as compacted by the previous blow when a stationary mounted type of rammer is used. During compaction, the mold assembly shall rest firmly on a dense, uniform, rigid, and stable foundation or base. This base shall remain stationary during the compaction process (Note 7).  
**Note 7**—Each of the following has been found to be a satisfactory base on which to rest the mold assembly during compaction of the soil: a block of concrete, with a mass of not less than 90 kg (200 lb), supported by a relatively stable foundation; a sound concrete floor; and for field application, such surfaces as are found in concrete box culverts, bridges, and pavements.
- 5.3.1. Following compaction, remove the collar; carefully trim the compacted soil even with the top of the mold by means of the straightedge, and determine the mass of the mold, base plate and moist soil in kilograms to the nearest 1 g (0.005 lb). Calculate the wet density,  $W_1$ , as described in Section 12.
- 5.4. Detach the base plate and remove the material from the mold using the extruder when necessary. Obtain a representative sample of the material by slicing vertically through the center of the molded material and removing one of the cut faces (Figure 3) or from the center of the pile if the material falls apart. Weigh the sample immediately. Determine the moisture content in accordance with T 265, and record the results.



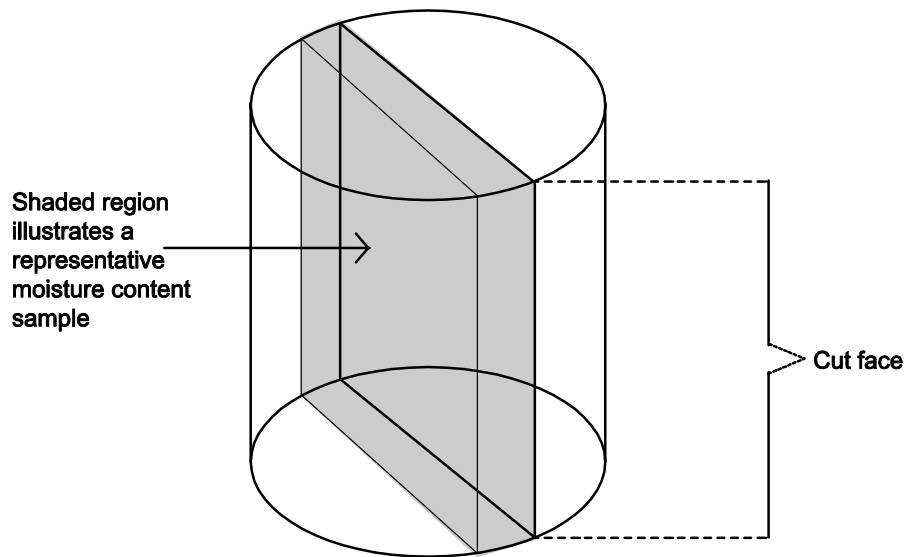

**Figure 3**—Representative Moisture Content Sample Selection

- 5.5. Thoroughly break up the remaining portion of the molded specimen until it will pass a 4.75-mm (No. 4) sieve as judged by eye, and add to the remaining portion of the sample being tested. Add water in sufficient amount to increase the moisture content of the soil by approximately one to two percentage points (water content increments should not exceed 2.5 percent, except when heavy clay soils or organic soils exhibiting flat elongated curves are encountered; then the water content increments may be increased to a maximum of 4 percent), and repeat the above procedure for each increment of water added. When the series of determinations indicate a decrease or no change in the wet unit mass,  $W_1$ , per cubic meter (cubic foot) of the compacted soil (Note 8) perform one more determination such that there is a minimum of two determinations over optimum moisture.
- 5.5.1. One additional determination over optimum moisture is sufficient for non-cohesive, drainable soils.
- 5.5.2. In instances where the soil material is fragile in character and will be reduced significantly in grain size by repeated compaction, a separate and new sample shall be used in each compaction test.
- Note 8**—In some cases where the soil is heavy-textured, clayey material into which it is difficult to incorporate water, a separate and new sample shall be used in each compaction test. In these cases, separate samples shall be thoroughly mixed with amounts of water sufficient to cause the moisture contents of the samples to vary by approximately two percentage points. The moisture contents selected shall bracket the optimum moisture content, thus providing samples which, when compacted, will increase in mass to the maximum density and then decrease in mass. The samples of soil–water mixtures shall be placed in covered containers and allowed to stand for not less than 12 h before making the moisture–density test.

---

## METHOD B

---

### 6. SAMPLE

- 6.1. Obtain a representative sample in accordance with Section 4 except that the sample shall have a mass of approximately 7 kg (16 lb).

---

## 7. PROCEDURE

- 7.1. Follow the same procedure as described for Method A in Section 5, except for the following: Form a specimen by compacting the prepared soil in the 152.40-mm (6-in.) mold assembly in five approximately equal layers to give a total compacted depth of about 125 mm (5 in.), each layer being compacted by 56 uniformly distributed blows from the rammer. Calculate the wet density,  $W_1$ , as described in Section 12.

---

## METHOD C

---

### 8. SAMPLE

- 8.1. Obtain a representative sample. This sample must be large enough that when the oversized (retained on the 19.0-mm ( $3/4$ -in.) sieve) particles are removed 5 kg (11 lb) or more of the sample remains.
- 8.2. Dry the sample until it becomes friable under a trowel. Drying may be in air or by use of a drying apparatus that is maintained at a temperature not exceeding 60°C (140°F). Thoroughly break up the aggregations in such a manner as to avoid reducing the natural size of individual particles.
- 8.3. Sieve soil over the 19.0-mm ( $3/4$ -in.) sieve. When the sample has oversized particles, see Annex A1.
- 8.4. Reduce the sample to a mass of 5 kg (11 lb) or more in accordance with R 76.

---

### 9. PROCEDURE

- 9.1. Determine the mass of the mold and base plate to the nearest 1 g (0.005 lb).
- 9.2. Thoroughly mix the selected representative sample with sufficient water to dampen it to approximately four to eight percentage points below optimum moisture content.
- 9.3. Form a specimen by compacting the prepared soil in the 101.60-mm (4-in.) mold assembly in five approximately equal layers to give a total compacted depth of about 125 mm (5 in.). Prior to compaction, place the loose soil into the mold assembly and spread into a layer of uniform thickness. Lightly tamp the soil prior to compaction until it is not in a loose or fluffy state, using either the manual compaction rammer or similar device having a face diameter of approximately 50 mm (2 in.). Following compaction of each of the first four layers, any soil adjacent to the mold walls that has not been compacted or extends above the compacted surface shall be trimmed using a knife or other suitable device, and be evenly distributed on top of the layer. Compact each layer by 25 uniformly distributed blows from a rammer dropping free from a height of 457 mm (18 in.) above the elevation of the soil when a sleeve-type rammer is used, or from 457 mm (18 in.) above the approximate elevation of each finely compacted layer when a stationary mounted type of rammer is used. During compaction, the mold assembly shall rest firmly on a dense, uniform, rigid, and stable foundation or base. This base shall remain stationary during the compaction process (Note 7).
- 9.3.1. Following compaction, remove the collar; carefully trim the compacted soil even with the top of the mold by means of the straightedge. Holes developed in the surface by removal of coarse material shall be patched with smaller-sized material. Determine the mass of the mold, base plate, and moist soil in kilograms to the nearest 1 g (0.005 lb). Calculate the wet density,  $W_1$ , as described in Section 12.

- 9.4. Detach the base plate and remove the material from the mold using the extruder when necessary. Obtain a representative sample of the material by slicing vertically through the center of the molded material and removing one of the cut faces (Figure 3) or from the center of the pile if the molded material falls apart. Weigh the sample immediately. Determine the moisture content in accordance with T 265 and record the results.
- 9.5. Thoroughly break up the remainder of the material until it will pass a 19.0-mm (0.75-in.) sieve and 90 percent of the soil aggregations will pass a 4.75-mm (No. 4) sieve as judged by eye, and add to the remaining portion of the sample being tested. Add water in sufficient amounts to increase the moisture content of the soil sample by one or two percentage points, and repeat the above procedure for each increment of water added (Note 8). When the series of determinations indicate a decrease or no change in the wet unit mass,  $W_1$ , per cubic meter (cubic foot) of the compacted soil perform one more determination such that there is a minimum of two determinations over optimum moisture.
- 9.5.1. One additional determination over optimum moisture is sufficient for non-cohesive, drainable soils.

---

## METHOD D

---

### 10. SAMPLE

- 10.1. Obtain a representative sample in accordance with Section 8, except that it shall have a mass of approximately 11 kg (25 lb).

---

### 11. PROCEDURE

- 11.1. Follow the same procedure as described for Method C in Section 9, except for the following: Form a specimen by compacting the prepared soil in the 152.40-mm (6-in.) mold assembly in five approximately equal layers to give a total compacted depth of about 127 mm (5 in.), each layer being compacted by 56 uniformly distributed blows from the rammer. Calculate the wet density,  $W_1$ , as described in Section 1.

---

## CALCULATIONS AND REPORT

---

### 12. CALCULATIONS

- 12.1. Wet density ( $W_1$ ) shall be determined using the mold volume. For masses recorded in kilograms, the unit of wet density is kilograms per cubic meter of compacted soil. For masses recorded in pounds, the unit of wet density is pounds per cubic foot of compacted soil.

$$W_1 = (A - B)/V \quad (1)$$

where:

$W_1$  = wet density in kg/m<sup>3</sup> (lb/ft<sup>3</sup>) of compacted soil,

$A$  = mass of the mold, base plate, and wet soil,

$B$  = mass of the mold, base plate,

$V$  = mold volume as determined in Section 3.1.1 for Methods A and C, or Section 3.1.2 for Methods B and D.

12.2. The dry density is related to the wet density as follows:

$$W = \frac{W_1}{w + 100} \times 100 \quad (2)$$

where:

$W$  = dry density, in kilograms per cubic meter of compacted soil, or pounds per cubic foot of compacted soil; and

$W_1$  = wet density in kg/m<sup>3</sup> (lb/ft<sup>3</sup>) of compacted soil,

$w$  = moisture content (percent) of the specimen.

---

## 13. MOISTURE–DENSITY RELATIONSHIP

13.1. The calculations in Section 12 shall be made to determine wet density (unit mass) and oven-dry density (unit mass) in kilograms per cubic meter or pounds per cubic foot for each of the compacted samples. The oven-dry densities of the soil shall be plotted as ordinates and corresponding moisture contents as abscissae.

13.2. *Optimum Moisture Content*—When the densities and corresponding moisture contents for the soil have been determined and plotted as indicated in Section 13.1, it will be found that by connecting the plotted points with a smooth line, a curve is produced. The moisture content corresponding to the peak of the curve shall be termed the “optimum moisture content” of the soil under the above compaction.

13.3. *Maximum Dry Density*—The oven-dry density in kilograms per cubic meter or pounds per cubic foot of the soil at optimum moisture content shall be termed “maximum density” under the above compaction.

---

## 14. REPORT

14.1. *The report shall include the following:*

14.1.1. The method used (Method A, B, C, or D);

14.1.2. The optimum moisture content to the nearest 0.1 percent;

14.1.3. The maximum density to the nearest 1 kg/m<sup>3</sup> (0.1 lb/ft<sup>3</sup>);

14.1.4. Type of face, if other than 50.8-mm (2-in.) circular;

14.1.5. Oversized particle correction:

14.1.5.1. The adjusted maximum dry density to the nearest 1 kg/m<sup>3</sup> (0.1 lb/ft<sup>3</sup>);

14.1.5.2. The corrected optimum moisture content to the nearest 0.1 percent;

14.1.5.3. The oversized particles to the nearest 0.1 percent of the original dry mass of the sample; and

14.1.5.4.  $G_{sb}$  of oversized particles to the nearest 0.001.

---

**15. KEYWORDS**

15.1. Compaction; moisture content; sieve; soil density; soil moisture.

---

**ANNEX A**

---

(Mandatory Information)

---

**A1. CORRECTION OF MAXIMUM DRY DENSITY AND OPTIMUM MOISTURE FOR OVERSIZED PARTICLES**

- A1.1. This section corrects the maximum dry density and moisture content of the material retained on the 4.75-mm (No. 4) sieve, Methods A and B; or the material retained on the 19.0-mm (<sup>3</sup>/<sub>4</sub>-in.) sieve, Methods C and D. The maximum dry density, adjusted for oversized particles and total moisture content, are compared with the field-dry density and field moisture content.
- A1.1.1. This correction can be applied to the sample on which the maximum dry density is performed.
- A1.1.2. This correction can also be applied to the sample obtained from the field while performing in-place density. Obtain the sample in accordance with T 310, Section 9.6. Sieve the sample over the appropriate sieve. Use the alternative drying method [see Section A1.3.2].
- A1.1.3. Correction may not be of practical significance for materials with only a small percentage of oversized particles. If a minimum percentage is not specified, correction shall be applied to samples with more than 5 percent by weight of oversized particles.
- A1.2. Bulk specific gravity ( $G_{sb}$ ) of the oversized particles is required to determine the corrected maximum dry density. If the bulk specific gravity has been determined in accordance with T 85, this value should be used in the calculations. For most construction activities, the specific gravity can be assumed to be 2.600.
- A1.3. Determine the dry mass of the oversized and fine fractions [ $M_{DC}$  and  $M_{DF}$ ].
- A1.3.1. If necessary dry the fractions, fine and oversized, in air or by use of a drying apparatus that is maintained at a temperature not exceeding 60°C (140°F).
- A1.3.2. Alternatively determine the moist mass of both fractions, fine ( $M_{Mf}$ ) and oversized ( $M_{Mc}$ ). Obtain moisture samples from the fine and oversized material. Determine the moisture content of the fine particles ( $MC_f$ ) and oversized particles ( $MC_c$ ) of the material. The moisture contents can be determined by T 265, T 217, or T 255. If the moisture content of the oversized particles is generally known, substitute that moisture content in the calculations.
- A1.3.2.1. Calculate the dry mass of the oversized and fine particles as follows:
- $$M_D = M_M / (1 + MC) \quad (A1.1)$$
- where:
- $M_D$  = mass of dry material (fine or oversized particles);
- $M_M$  = mass of moist material (fine or oversized particles); and
- $MC$  = moisture content of respective fine or oversized particles, expressed as a decimal.
- A1.4. Calculate the percentage of the fine particles and oversized particles by dry weight of the total sample as follows:

$$P_f = 100 M_{DF} / (M_{DF} + M_{DC}) \quad (A1.2)$$

and

$$P_C = 100 M_{DC} / (M_{DF} + M_{DC}) \quad (A1.3)$$

where:

$P_f$  = percent of dry fine particles;

$M_{DF}$  = mass of dry fine particles;

$M_{DC}$  = mass of dry oversized particles; and

$P_C$  = percent of oversized particles of sieve used.

- A1.5. Calculate the corrected optimum moisture content of the total sample (combined fine and oversized particles) as follows:

$$MC_T = (MC_f P_f + MC_C P_C) / 100 \quad (A1.4)$$

where:

$MC_T$  = corrected optimum moisture content of the total sample expressed as a decimal,

$MC_f$  = optimum moisture content of the fine particles, expressed as a decimal,

$P_f$  = percent of fine particles of sieve used,

$MC_C$  = moisture content of the oversized particles, expressed as a decimal; and

$P_C$  = percent of oversized particles of sieve used.

- A1.6. Calculate the corrected dry density of the total sample (combined fine and oversized particles) as follows:

$$D_d = 100 D_f k / (D_f P_C + k P_f) \quad (A1.5)$$

$$\text{Equivalent formula: } D_d = \frac{100}{\frac{P_f}{D_f} + \frac{P_C}{k}} \quad (A1.6)$$

where:

$D_d$  = corrected maximum dry density of the total sample, kg/m<sup>3</sup> (lb/ft<sup>3</sup>),

$D_f$  = maximum dry density of the fine particles, kg/m<sup>3</sup> (lb/ft<sup>3</sup>),

$k$  = 1000 × Bulk Specific Gravity ( $G_{sb}$ ) (oven-dry basis) of coarse particles, kg/m<sup>3</sup>; or 62.4 × Bulk Specific Gravity ( $G_{sb}$ ) (oven-dry basis) of coarse particles, lb/ft<sup>3</sup>,

$P_C$  = percent of oversized particles of sieve used, and

$P_f$  = percent of fine particles of sieve used.